

**KRN HEAT EXCHANGER &  
REFRIGERATION LIMITED**

# PRODUCT

Seamless Integration, Superior Performance:  
India's Finned Tube Heat Exchangers for Global HVAC&R

# CATALOGUE



# KRN Heat Exchanger at a glance

A leading manufacturer & exporter of fin and tube type condenser and evaporator coils for OEMs in heating, ventilation, air conditioning and refrigeration (HVAC&R) industry.

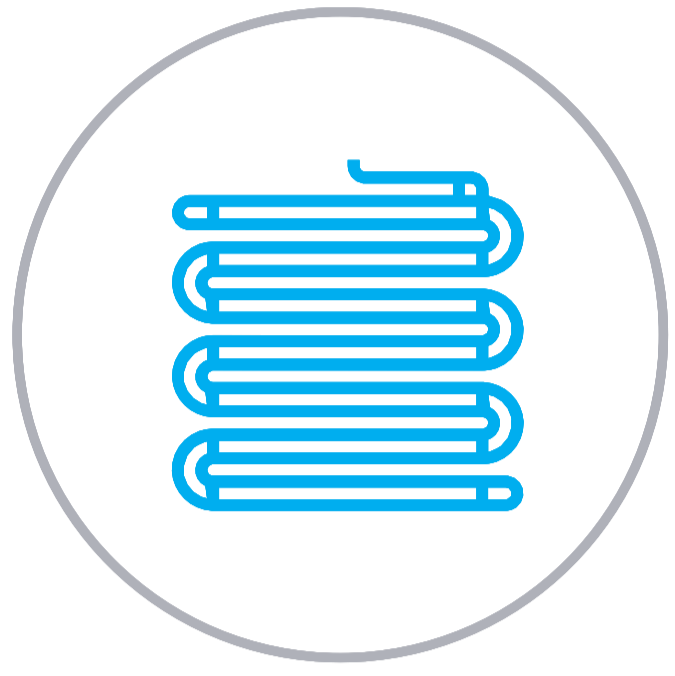

## Expertise in

Fin & Tube Type Heat Exchanger



## Trusted Customers

200+ Trusted Customers

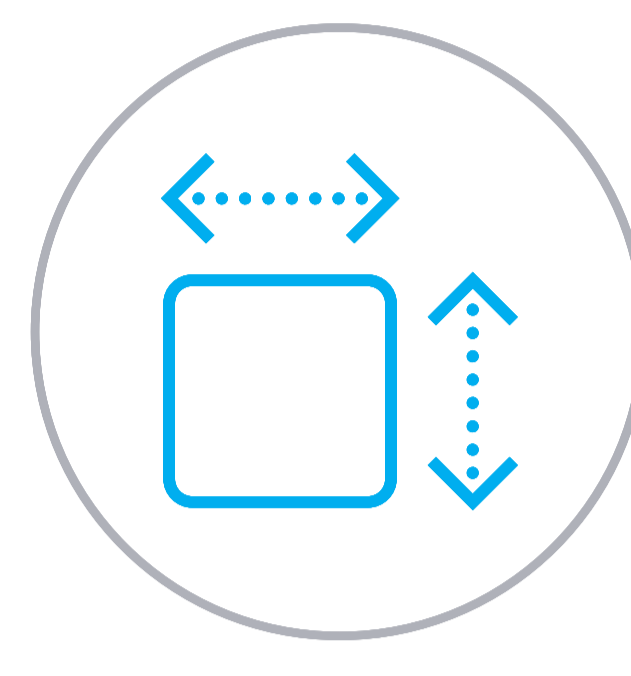

## Factory Area

Spread across 9,00,000 Sq. ft



## Founded

Year 2017 in Neemrana, India



## VISION

To attain and maintain the position of Leadership through unwavering dedication, innovative thinking, and an unwavering passion.

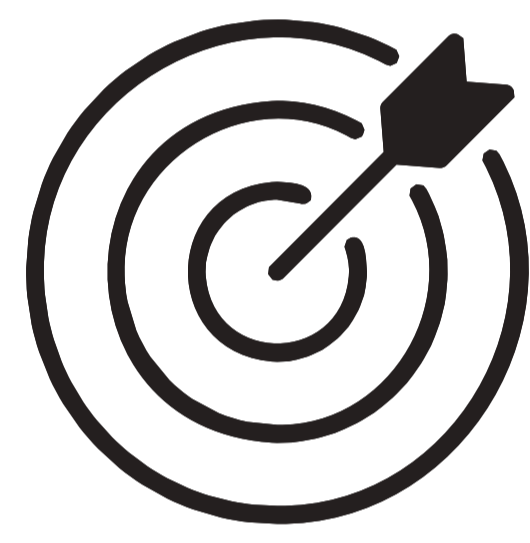

## MISSION

Our primary objective is to enhance the value provided to our clients by delivering cost-effective products and services through the seamless integration of human resources, technological advancements, organizational processes, and business systems.



## VALUES

To deliver exceptional custom solutions that adhere to international standards, we are committed to continuously enhancing our products and processes to achieve enduring results.

## CERTIFICATIONS

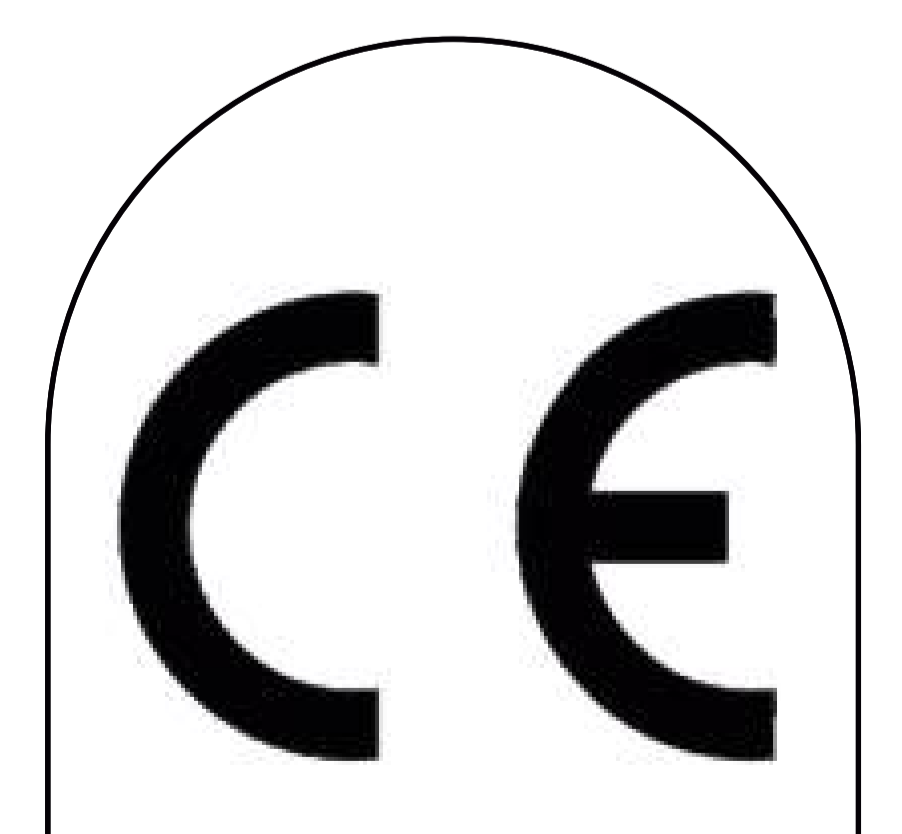
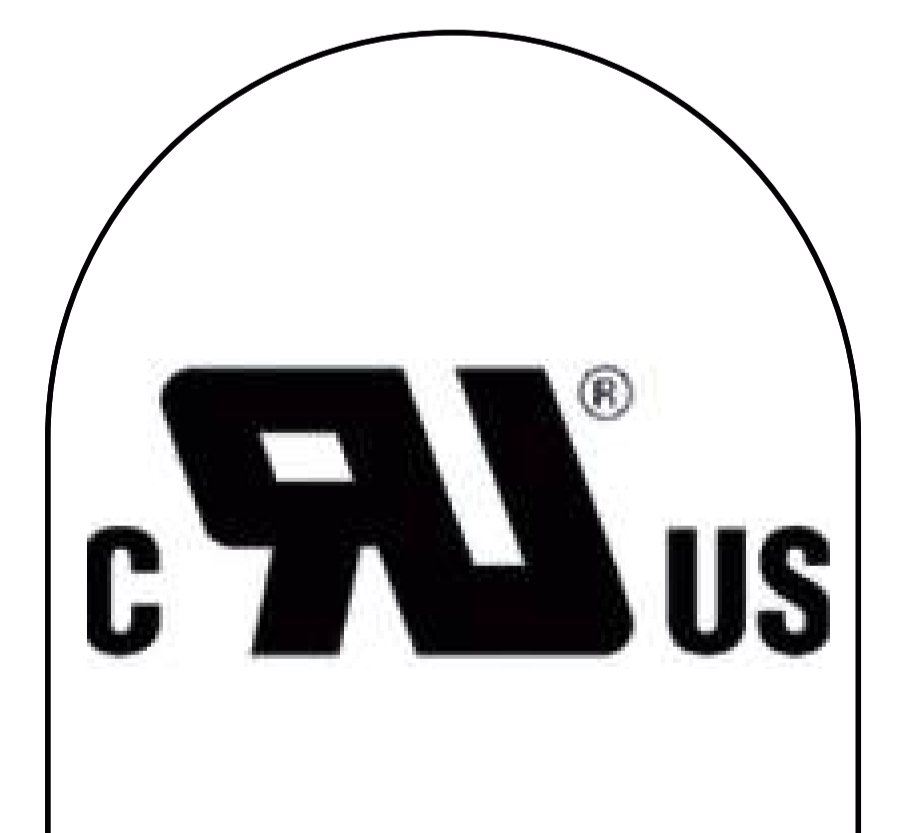
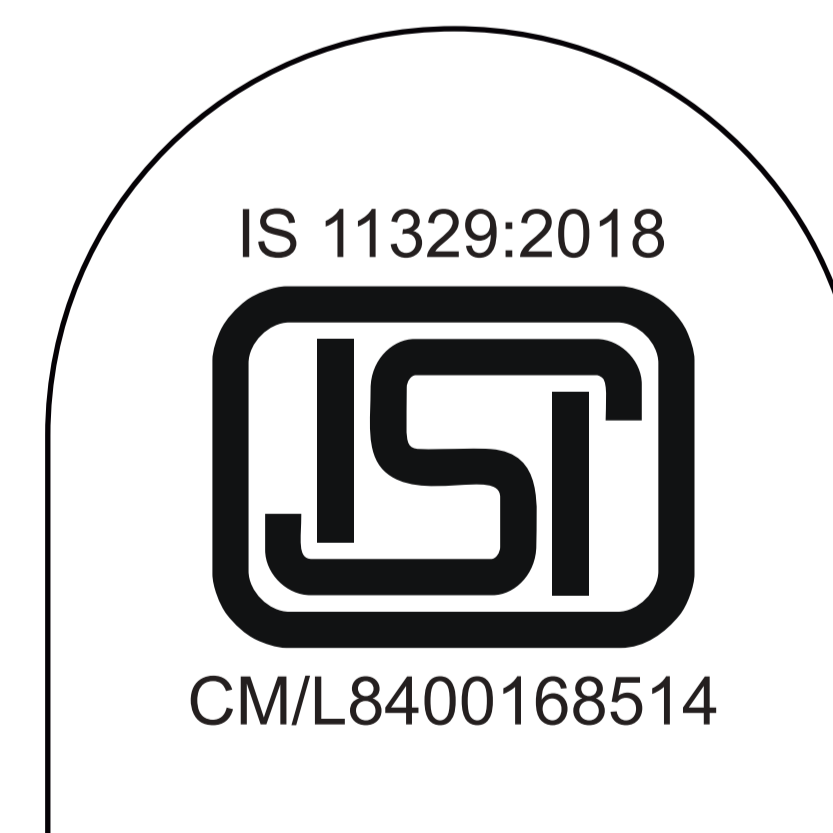

# PRODUCT RANGE

- **Customized to Your Specific Requirements:** Benefit from unparalleled customization options tailored to your unique needs.
- **Timely Delivery:** Your products will be delivered to you within four weeks (excluding shipping time), ensuring efficient project planning.
- **Extensive Design Expertise:** Leverage our extensive design expertise, garnered over two decades of industry experience, to enhance your design endeavors.
- **Safety Assurance:** Rest assured with UL-approved coils that adhere to stringent safety standards.

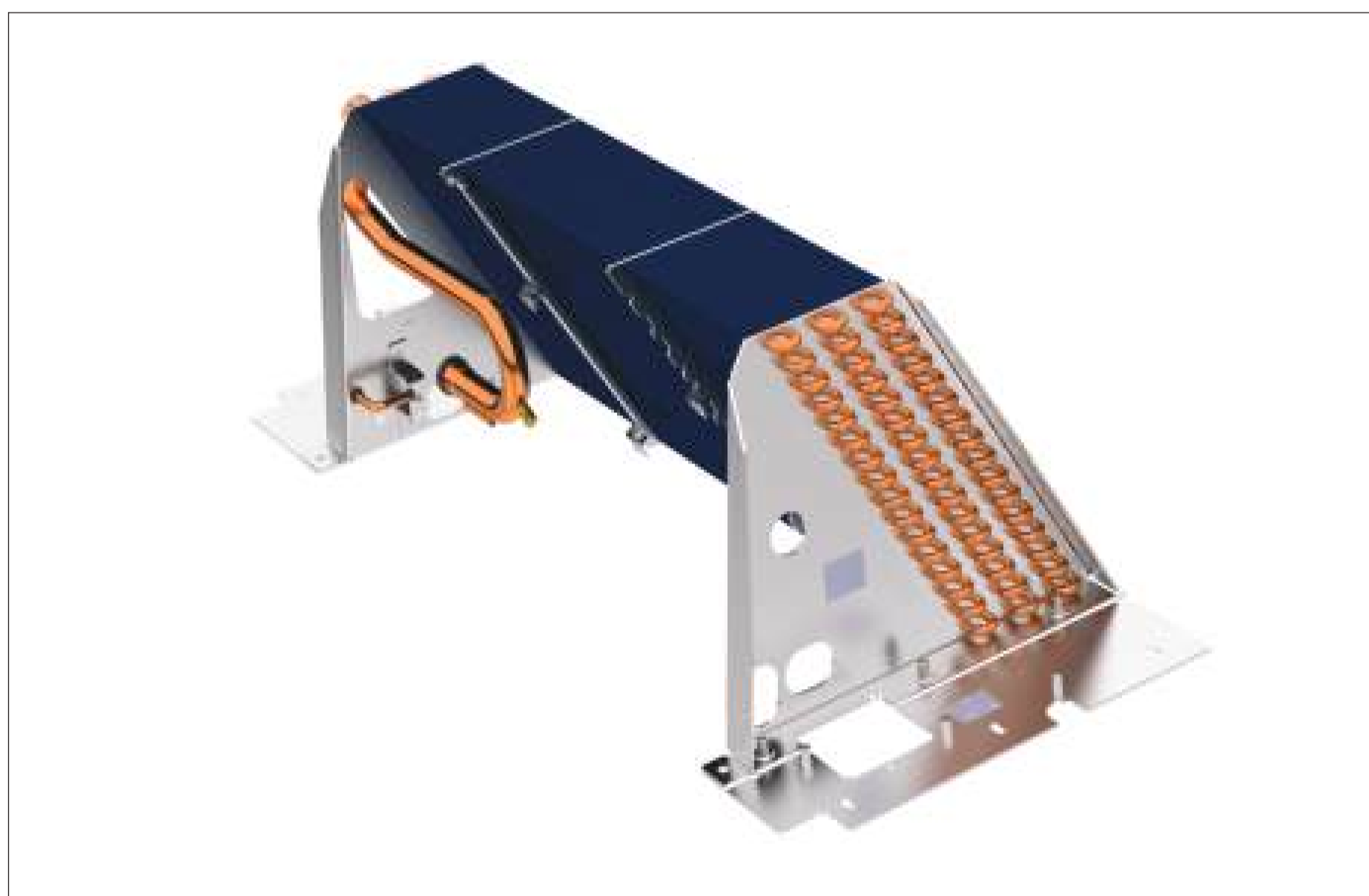

**FIN & TUBE**

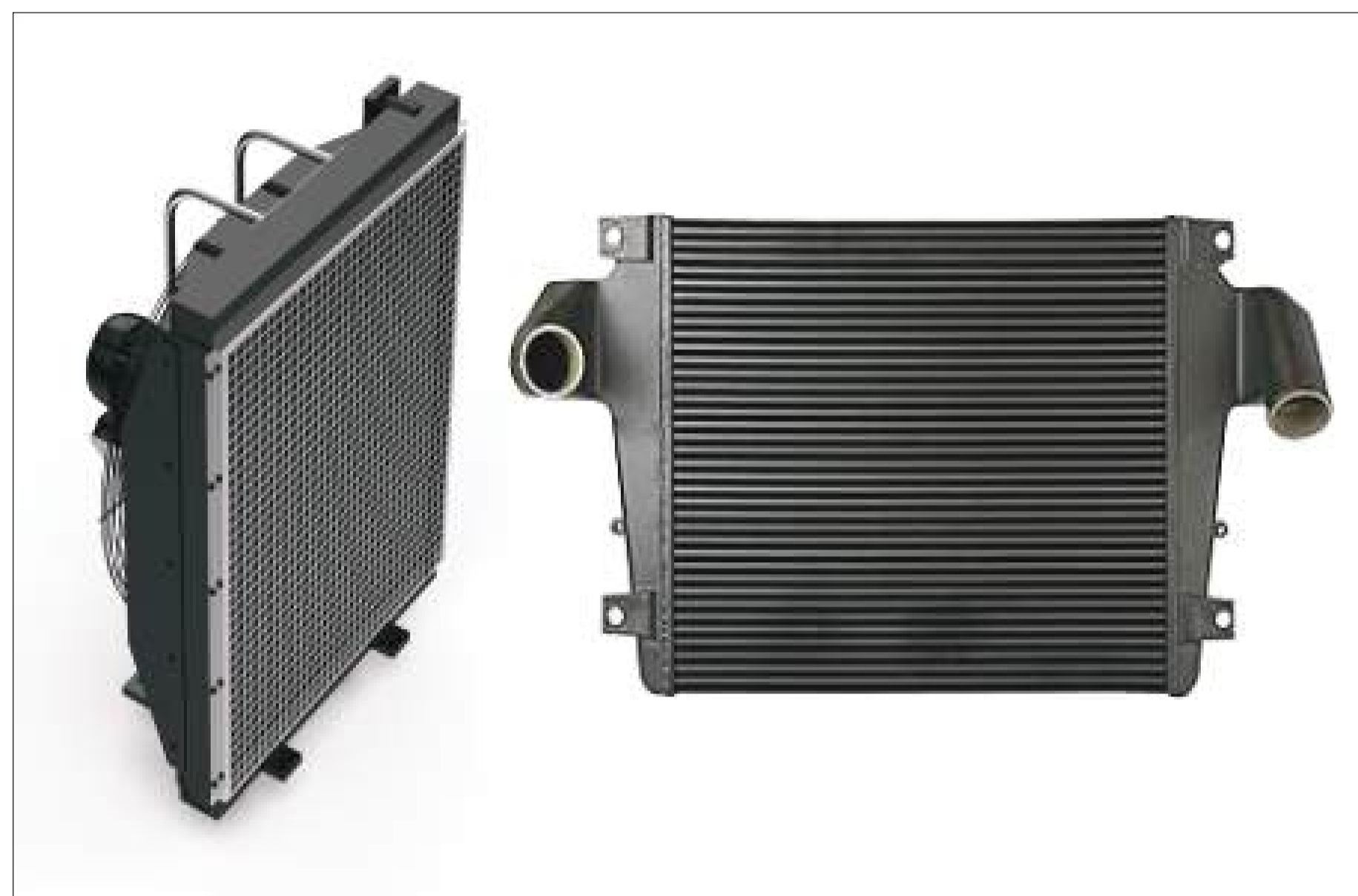

**BAR & PLATE**

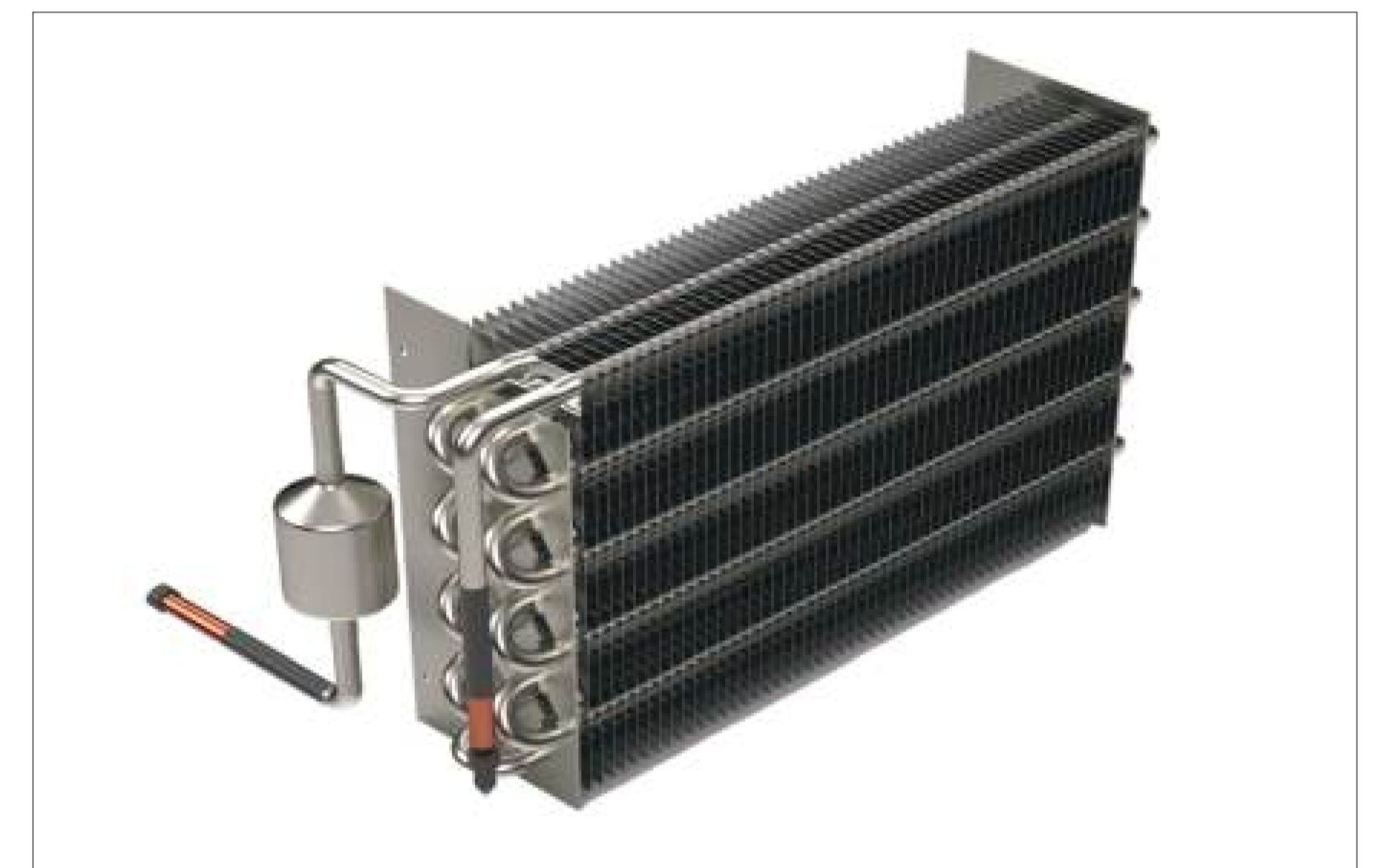

**REFRIGERATOR COMPONENTS**



**REFRIGERATION**



**COMPLETE HVAC SYSTEM**



**MICRO CHANNELS**



**BUS AC**



**TECHNICAL TUBES**



**TUBINGS**

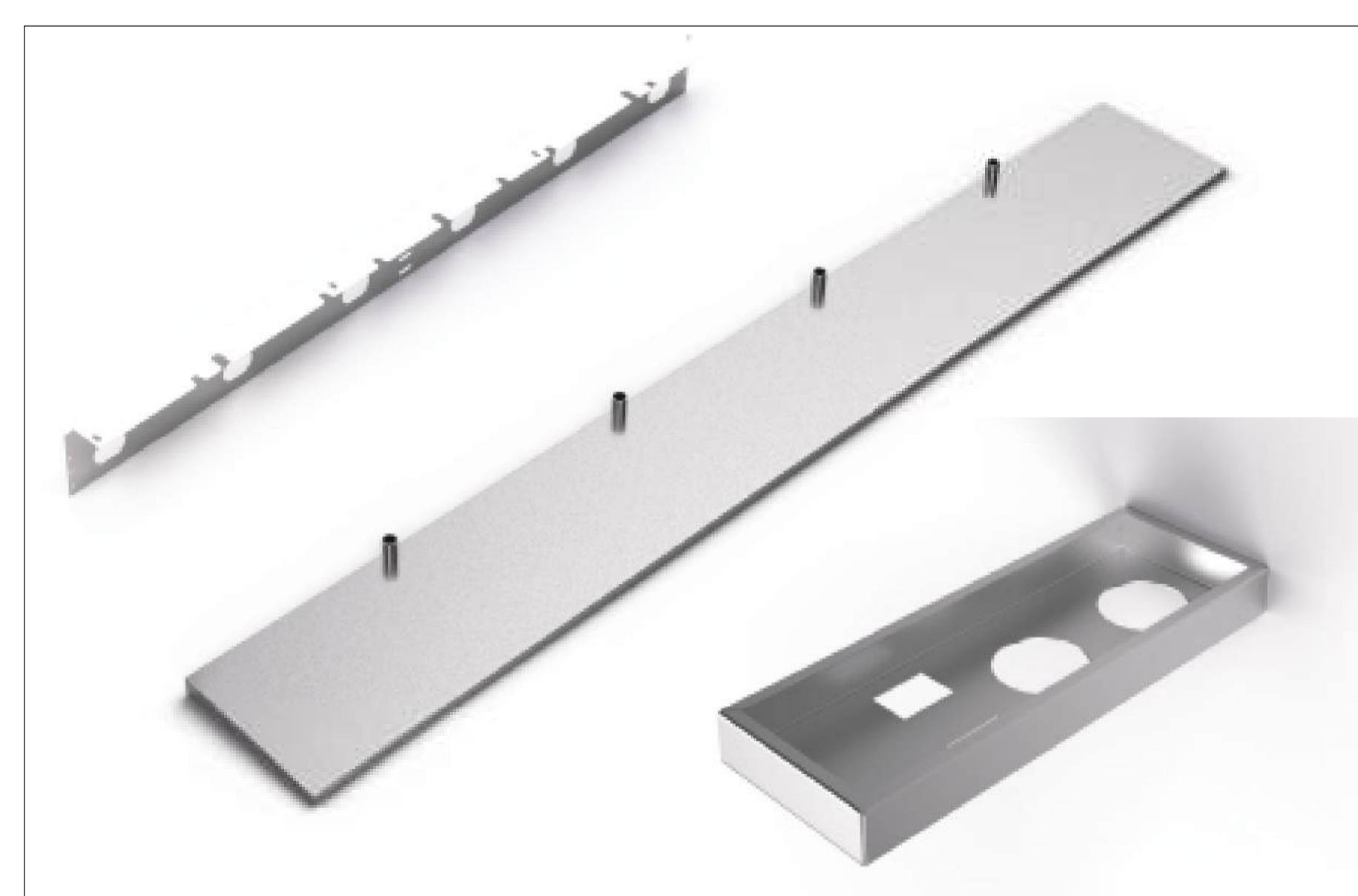

**SHEET METAL**

# GEOMETRY

Tube OD	5 mm	5 mm	5 mm	5 mm	6.35 mm	7 mm	7 mm	7 mm
Tube Pitch	19.05 mm	19.05 mm	25mm	20 mm	19.05 mm	21 mm	22 mm	25 mm
Row Pitch	16.5 mm	11.4 mm	21.65 mm	17.32 mm	16.5 mm	12.7 mm	19.05 mm	21.65 mm
Fin Thickness (mm)	0.095 ~ 0.25	0.095 ~ 0.25	0.095 ~ 0.30	0.095 ~ 0.30	0.095 ~ 0.30	0.095 ~ 0.30	0.095 ~ 0.25	0.095 ~ 0.25
FPI (mm)	8 ~ 22	11 ~ 22	5 ~ 22	5 ~ 22	5 ~ 22	8 ~ 22	7 ~ 22	7 ~ 22
Expansion Length (mm)	150 ~ 8000	150 ~ 4000	150 ~ 7000	150 ~ 7000	150 ~ 12000	150 ~ 2500	150 ~ 2500	150 ~ 12000
7.94 mm	7.94 mm	7.94 mm	9.52mm	9.52 mm	9.52 mm	12.7 mm	12.7 mm	15.88mm
25 mm	25.4 mm	25.4 mm	25.4 mm	25.4 mm	25.0 mm	30.0 mm	31.75 mm	50 mm
19.05 mm	19.05 mm	15.88 mm	15.88 mm	22 mm	21.65 mm	26.0 mm	27.5 mm	50 mm
0.095 ~ 0.30	0.095 ~ 0.30	0.095 ~ 0.30	0.095 ~ 0.30	0.095 ~ 0.30	0.095 ~ 0.30	0.095 ~ 0.30	0.095 ~ 0.30	0.095 ~ 0.30
5 ~ 22	5 ~ 22	5 ~ 22	3 ~ 22	3 ~ 22	4 ~ 22	3 ~ 22	4 ~ 20	2 ~ 16
150 ~ 12000	150 ~ 12000	150 ~ 12000	150 ~ 12000	150 ~ 12000	150 ~ 12000	150 ~ 12000	150 ~ 12000	150 ~ 12000



# FIN & TUBE

At KRN Heat Exchanger & Refrigeration Ltd., our Fin & Tube solutions are engineered to deliver maximum thermal efficiency and long-lasting reliability. Designed with advanced manufacturing techniques, these coils provide excellent heat transfer performance in both cooling and heating applications. With the flexibility to handle water, steam, refrigerants, or specialized fluids, our Fin & Tube coils are widely used in HVAC systems, industrial chillers, process cooling, and refrigeration equipment. Built with high-quality copper tubes, aluminum fins, and durable coatings for enhanced corrosion resistance, these coils ensure optimal performance even in demanding environments. Whether for new system integration or replacement, our Fin & Tube solutions guarantee energy efficiency, easy customization, and consistent results.

<b>EVAPORATOR COIL</b>	<b>CONDENSER COIL</b>	<b>FLUID &amp; STEAM COIL</b>	<b>HEATING COIL</b>
<b>SS COIL</b>	<b>CHILLED WATER COIL</b>	<b>SEA WATER COIL</b>	<b>FLOATING TYPE COIL</b>



**FLUID & STEAM COIL**

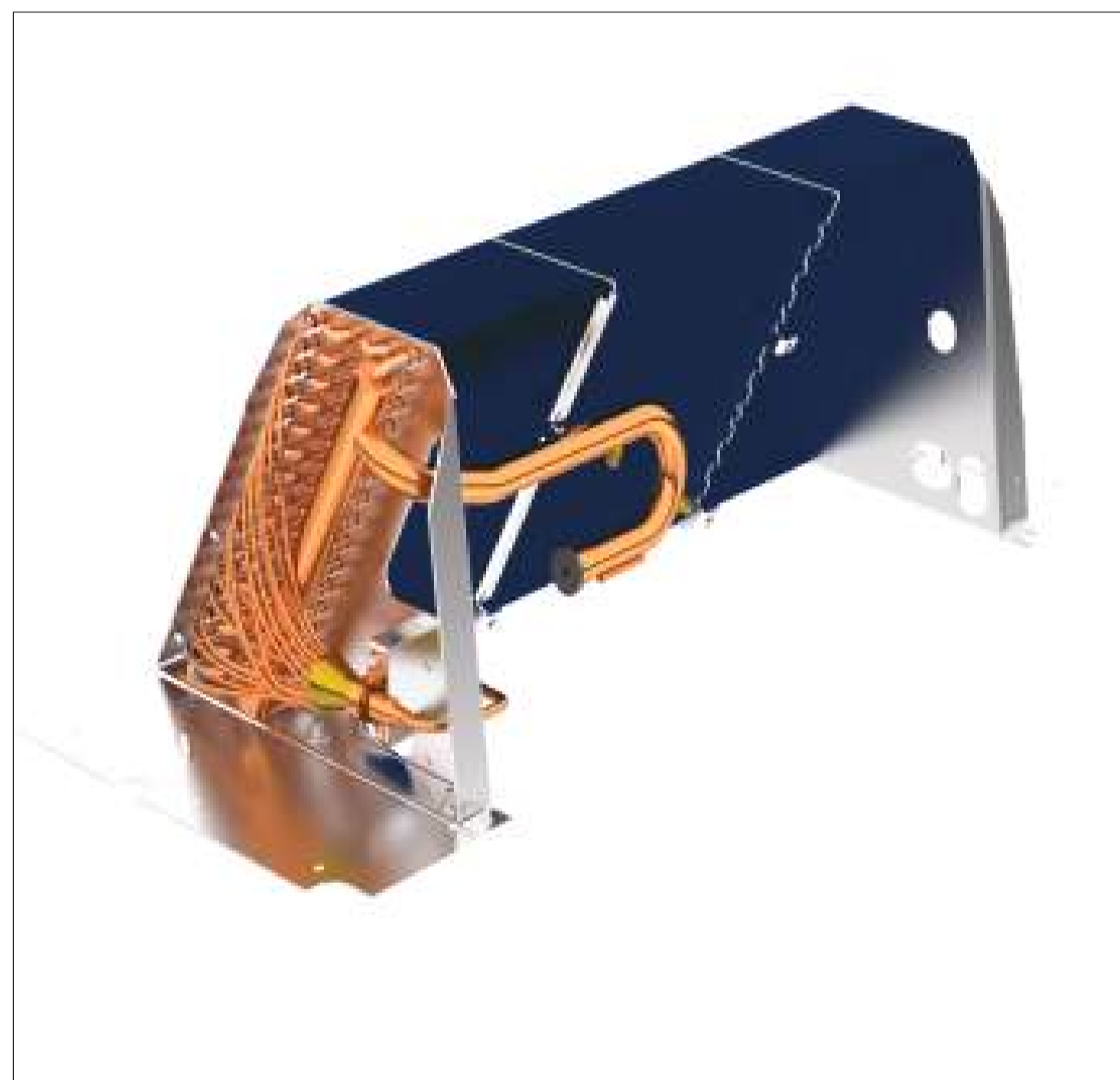

**EVAPORATOR COIL**



**CHILLED WATER COIL**

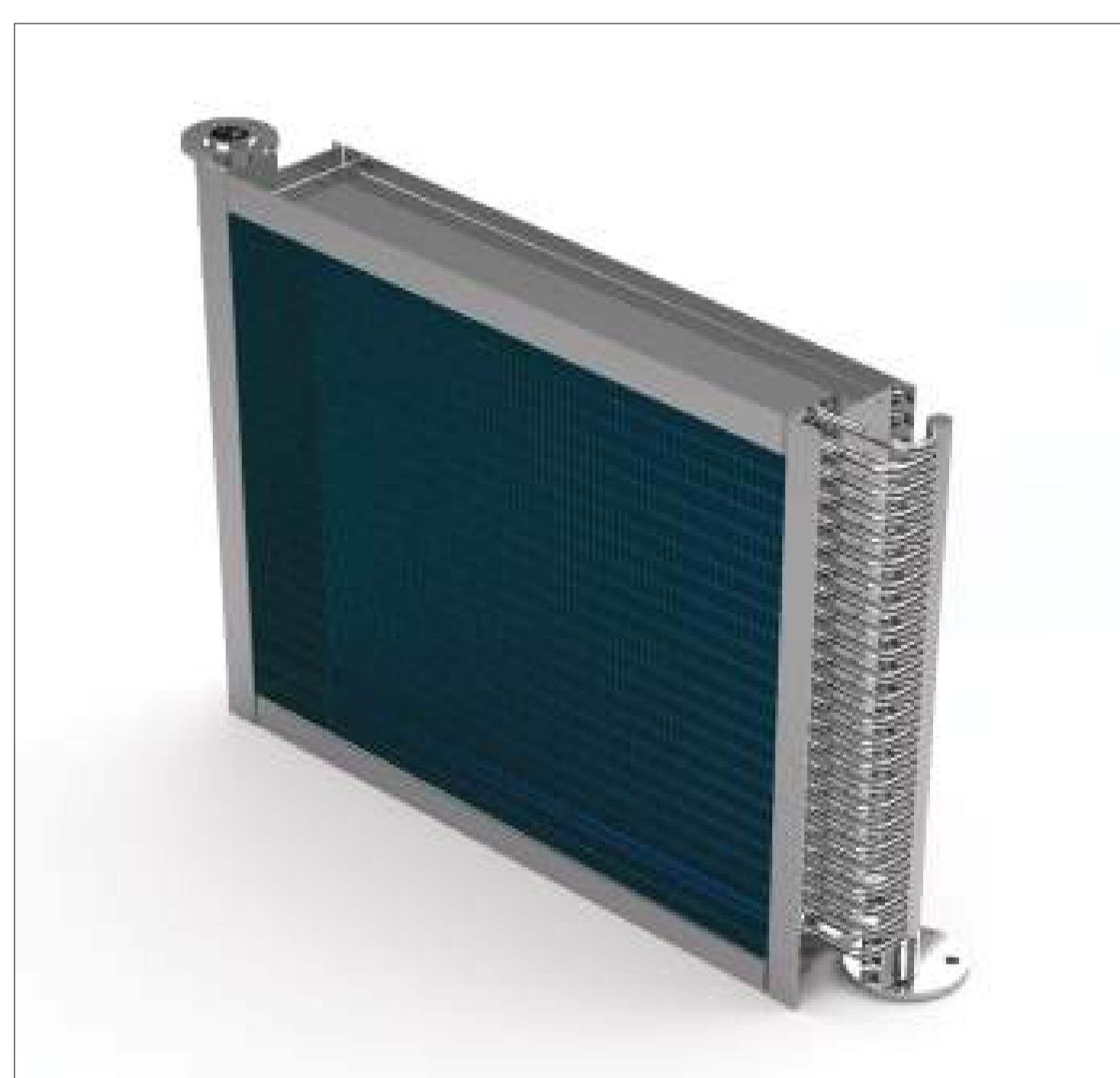

**SS COIL**



**HEATING COIL**



**FLOATING TYPE COIL**

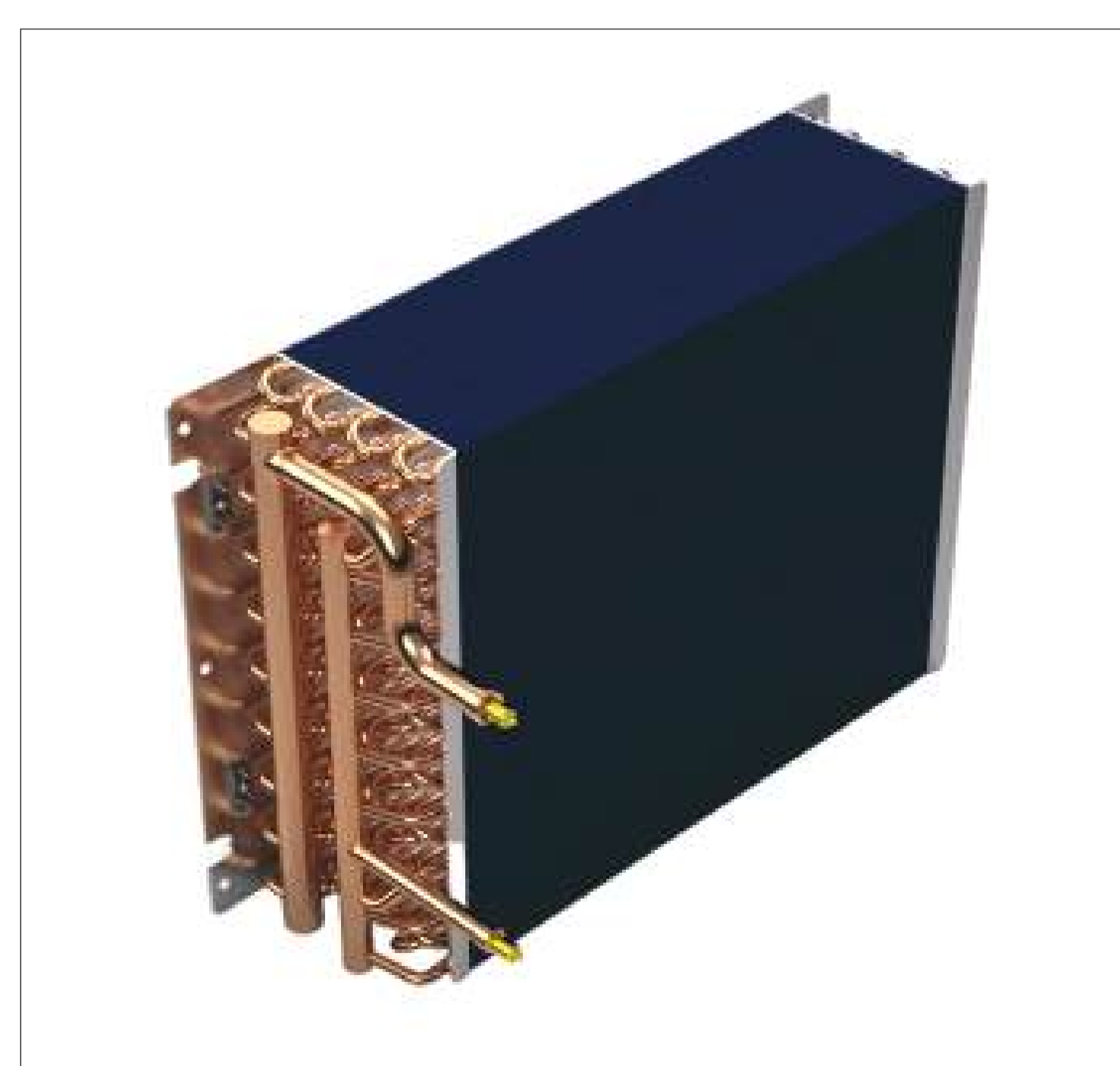

**CONDENSER COIL**



**SEA WATER COIL**

# BAR & PLATE

Our Bar & Plate heat exchangers are designed for compact, rugged, and high-performance cooling in industries where reliability cannot be compromised. Known for their superior thermal efficiency and structural strength, these exchangers are capable of withstanding high operating pressures, temperature fluctuations, and extreme conditions. Suitable for oil cooling, water cooling, air cooling, and mixed-fluid applications, they are extensively used in automotive, construction, marine, power generation, and industrial systems. With customizable flow arrangements, mounting designs, and protective coatings, KRN Bar & Plate exchangers provide versatile solutions tailored to specific customer needs. Their robust design ensures reduced downtime, extended equipment life, and superior system protection.

<b>WATER COOLER</b>	<b>OIL COOLER</b>	<b>CHARGE AIR COOLER</b>	<b>COMBI OIL COOLER</b>
<b>CONVERTER COOLER</b>	<b>RADIATOR</b>	<b>TRANSFORMER OIL COOLER</b>	<b>OFFLINE OIL COOLER</b>



**RADIATOR**



**OIL COOLER**



**CHARGE AIR COOLER**



**WATER COOLER**



**TRANSFORMER OIL COOLER**



**CONVERTER COOLER**



**OFFLINE AIR OIL COOLER**



**COMBI OIL COOLER**

# REFRIGERATOR COMPONENTS

KRN manufactures a comprehensive range of refrigerator components that combine energy efficiency, precision engineering, and reliable cooling performance. From evaporator coils to condensers and custom assemblies, our components are designed to meet the requirements of both residential and commercial refrigeration systems. Built with advanced materials and anti-corrosion treatments, they ensure consistent cooling while minimizing energy consumption and extending the service life of refrigerators and freezers. Our solutions support diverse applications such as household appliances, cold storage units, display cabinets, and commercial cooling equipment. With a focus on durability, low maintenance, and cost-efficiency, KRN refrigerator components are trusted by OEMs and system integrators worldwide.

**FROST FREE  
EVAPORATOR**

**WIRE ON  
TUBE CONDENSER**

**ROLL BOND  
EVAPORATOR**

**SKIN  
CONDENSER**

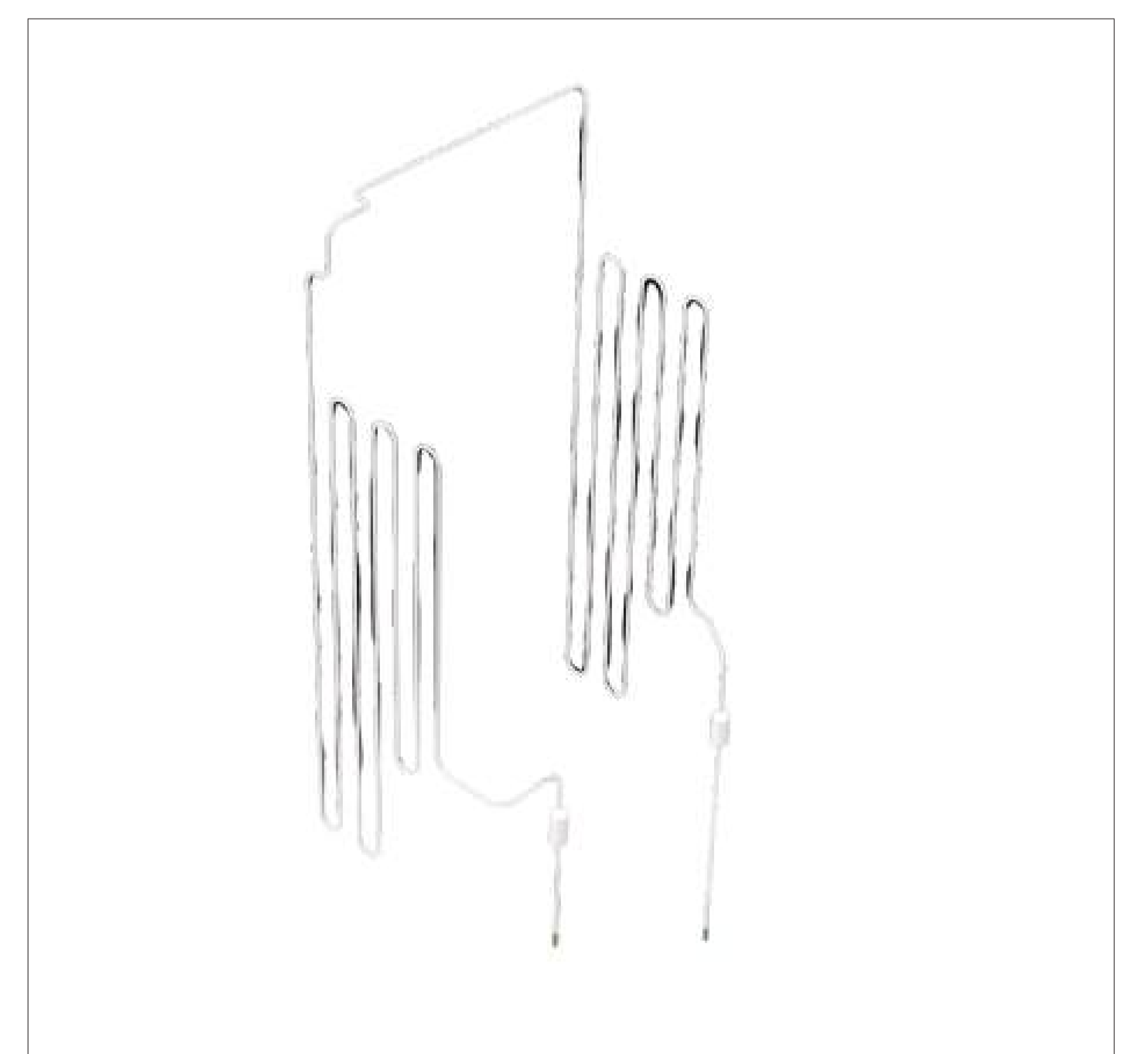

**FROST FREE EVAPORATOR**

**FROST FREE EVAPORATOR**

**SKIN CONDENSER**

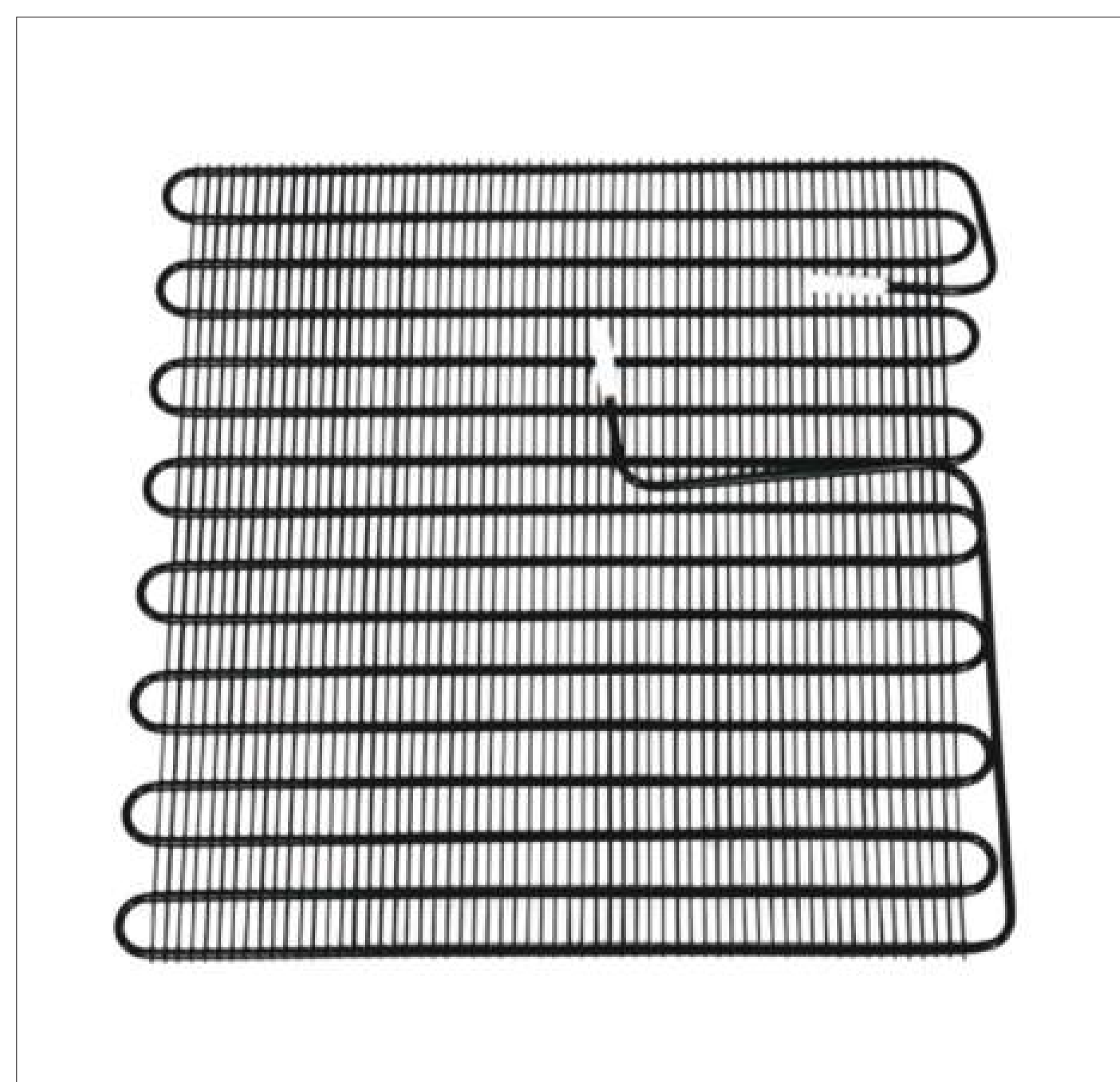

**WIRE ON TUBE CONDENSER**

**WIRE ON TUBE CONDENSER**

**ROLL BOND EVAPORATOR**

# REFRIGERATION

At KRN, our Refrigeration solutions are tailored to meet the diverse demands of cold chain, commercial, and industrial applications. We offer indoor and outdoor units, rack systems, and condensing units that provide stable cooling performance across varied load conditions. Designed for energy efficiency and long-term reliability, our refrigeration systems ensure precise temperature control for industries such as food storage, pharmaceuticals, hospitality, and retail. With robust designs, eco-friendly refrigerant compatibility, and easy installation options, our solutions guarantee cost-effective operation and minimal downtime. From small-scale cold rooms to large-scale industrial refrigeration plants, KRN delivers technology-driven solutions for dependable cooling.

**AIR COOLING UNITS**

**ODU**

**AMMONIA EVAPORATOR**

**BLAST FREEZERS**



**AMMONIA EVAPORATOR**



**BLAST FREEZER - CEILING MOUNTED**



**BLAST FREEZER - FLOOR MOUNTED**



**DUAL DISCHARGE AIR COOLING UNIT - IDU**



**FLOOR MOUNTED SPECIAL AIR COOLING UNIT - IDU**



**RACK REFRIGERATION SYSTEMS - ODU**



**SCROLL CONDENSING UNIT - ODU**



**SINGLE DISCHARGE AIR COOLING UNIT - IDU**

# COMPLETE HVAC SYSTEM

KRN's Complete HVAC Systems represent a fully integrated solution for modern air conditioning, heating, and ventilation needs. Designed with advanced engineering and sustainable practices, our systems deliver superior indoor air quality, energy efficiency, and long service life. Each system combines high-performance heat exchangers, compressors, fans, and controls to ensure seamless operation in commercial, industrial, and residential applications. With options ranging from packaged units to custom-designed HVAC solutions, KRN meets the unique requirements of every client. Our systems are engineered to minimize energy costs, reduce carbon footprint, and provide consistent comfort even in extreme climate conditions. Backed by global standards and rigorous quality testing, KRN HVAC solutions stand out for their durability, efficiency, and reliability.

## DRY COOLERS

## LT-HT Remote Radiators

## Adiabatic Coolers



**ADIABATIC COOLERS**

**DRY COOLERS (FLAT BED-TYPE)**

**DRY COOLERS (H-TYPE)**



**DRY COOLERS (V-TYPE)**

**LT HT REMOTE RADIATOR**

# MICRO CHANNELS

Our Micro Channel Heat Exchangers are the next-generation solution for compact, lightweight, and highly efficient thermal management. Offering superior heat transfer per unit volume, they drastically reduce refrigerant charge requirements and improve overall system efficiency. Designed with aluminum micro-channel technology, these exchangers deliver enhanced corrosion resistance, high mechanical strength, and long-term performance in demanding environments. Widely adopted in HVAC, refrigeration, automotive, and renewable energy applications, they represent a sustainable and energy-efficient choice for industries worldwide. With flexible design options, ease of installation, and reduced maintenance, KRN micro channel exchangers set the benchmark for innovation and performance in modern cooling technology.

## Domestic Micro Channel

## Automobile Micro Channel

## Commercial Micro Channel

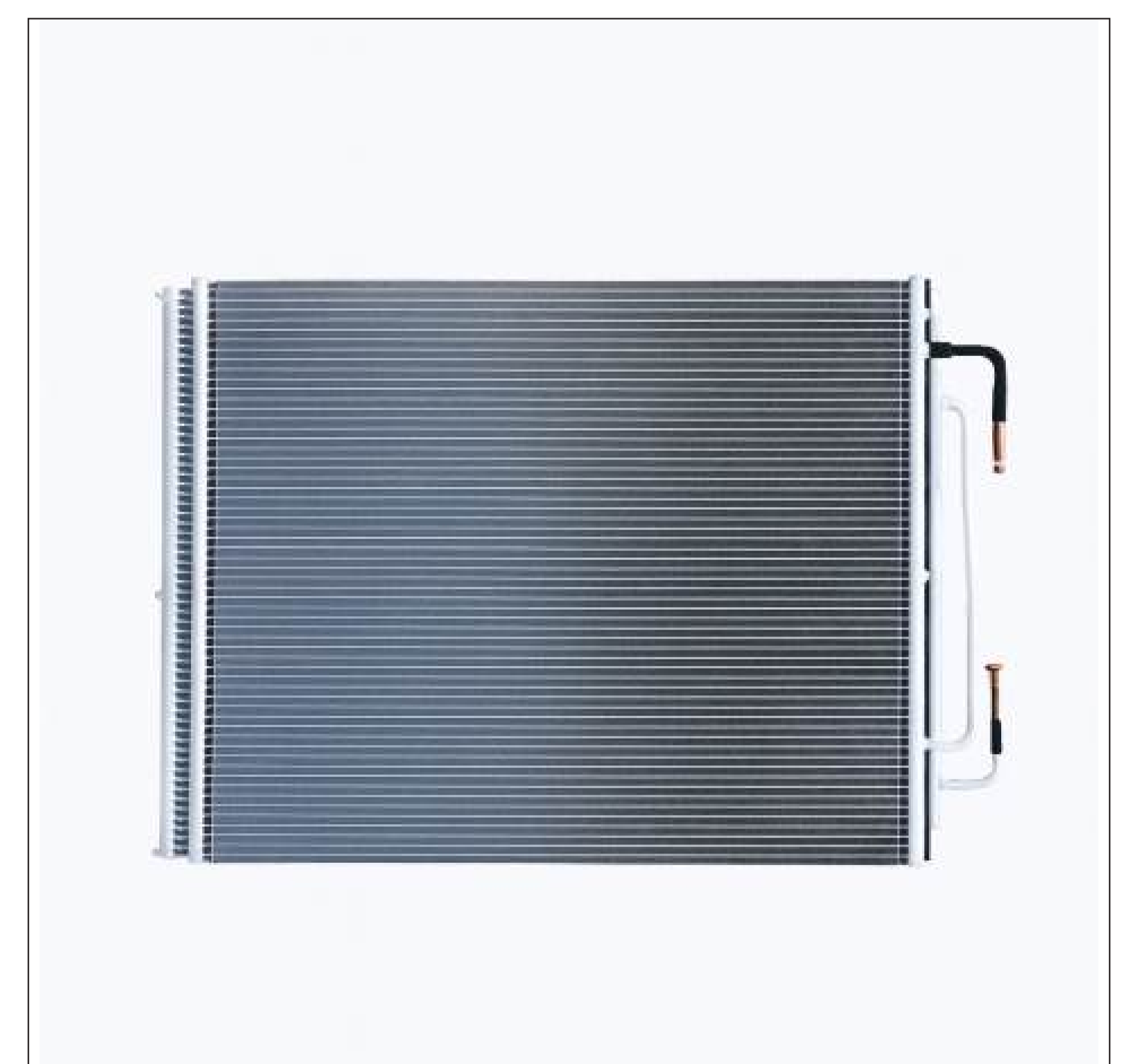

# BUS AC

With KRN's legacy and innovation-driven approach, the company brings a new standard of quality to bus air-conditioning and emergency-exit systems. Our focus is simple — consistent performance, stronger safety, and trusted dependability. From public transport to defence platforms, our systems are designed for dependable cooling, smart energy use, and long-term operational value. We develop dedicated solutions for electric and diesel buses, railway applications, transport cooling units, mission-ready defence HVAC modules, and next-generation thermal systems for electric vehicles.

**Electric Bus  
Air Conditions**

**Ice Bus  
Air Conditions**

**Roof  
Hatch**

**Battery  
Cooling**



**XELA9A**



**XELA12A**

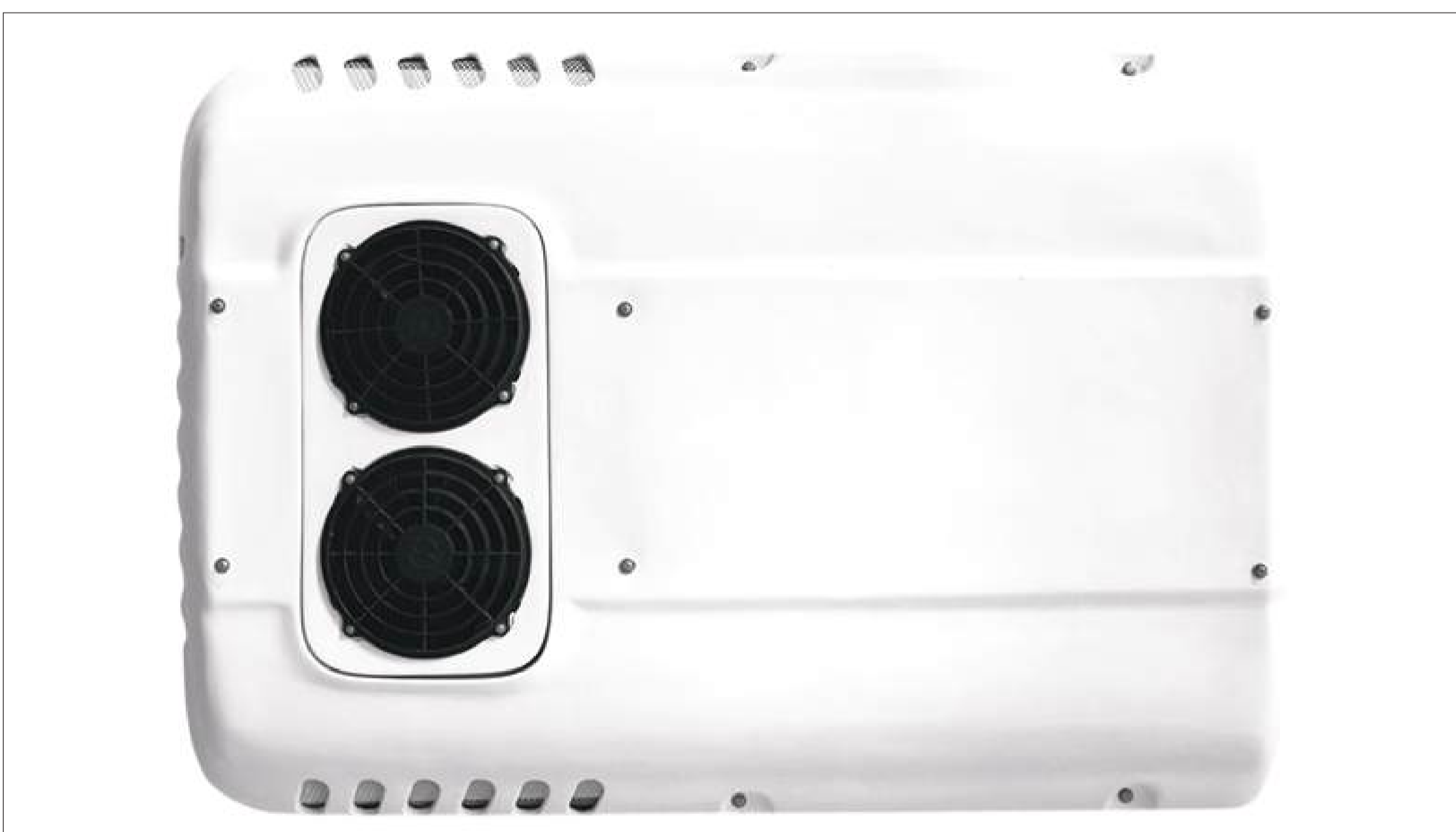

**XPE12**

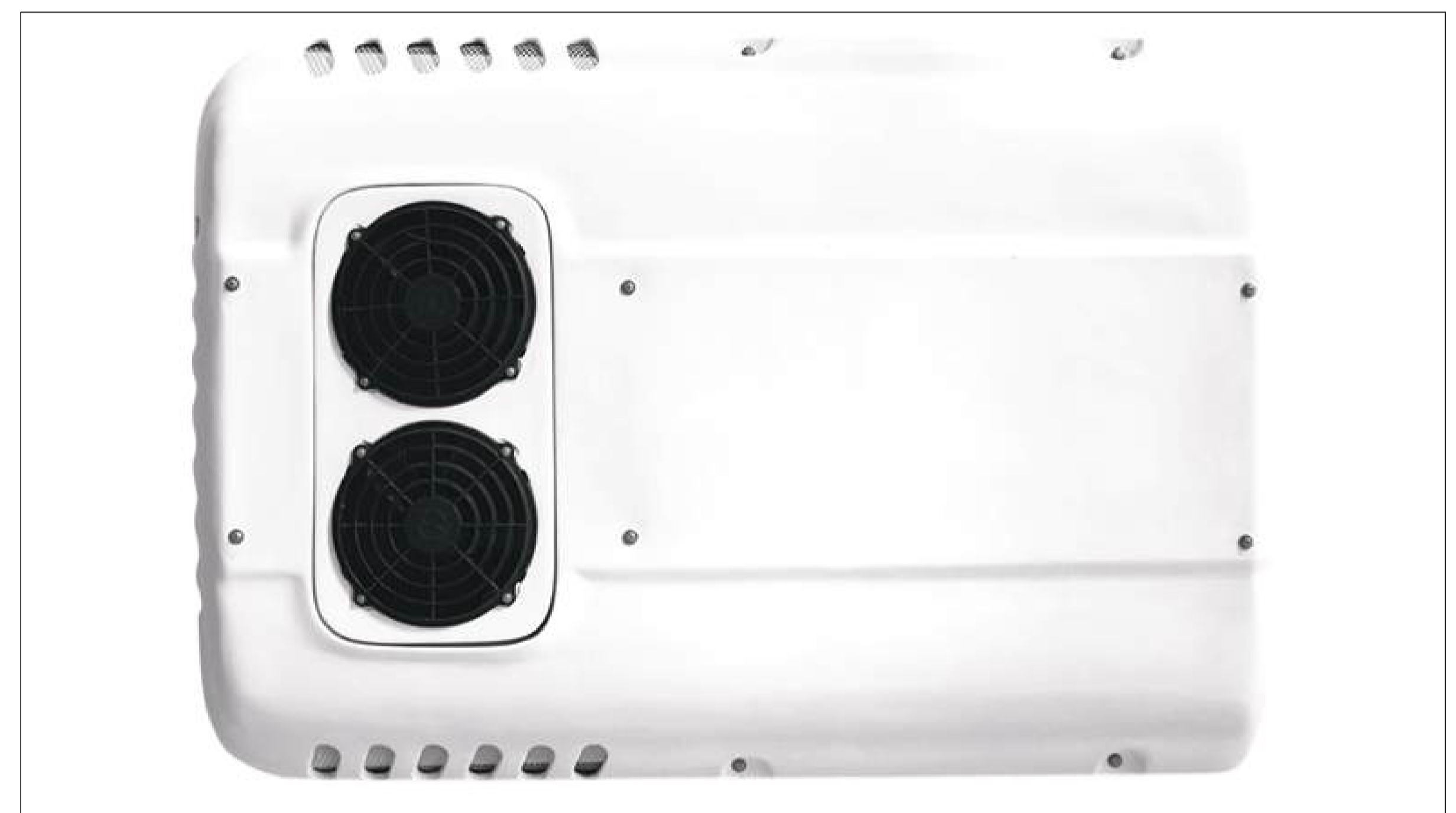

**ZNC12**



**Roof Hatch**



**Battery Cooling**

# TECHNICAL TUBES

KRN manufactures high-performance copper finned tubes featuring precision-engineered outer finned surfaces and inner grooved profiles, specifically designed for shell & tube heat exchanger applications in chiller systems. A variety of external fin profiles and internal groove configurations are available to optimize heat transfer efficiency. These tubes are manufactured with strict quality controls to ensure dimensional accuracy that making them highly reliable under demanding cooling conditions. Their robust design and superior thermal performance make them ideal for use in industrial chillers, HVAC systems, and other high-efficiency cooling applications.



## Finned Tubes

**INNER  
GROOVED**

**OUTER  
GROOVED**

**INNER OUTER  
GROOVED**

**LOW & MEDIUM  
GROOVED**

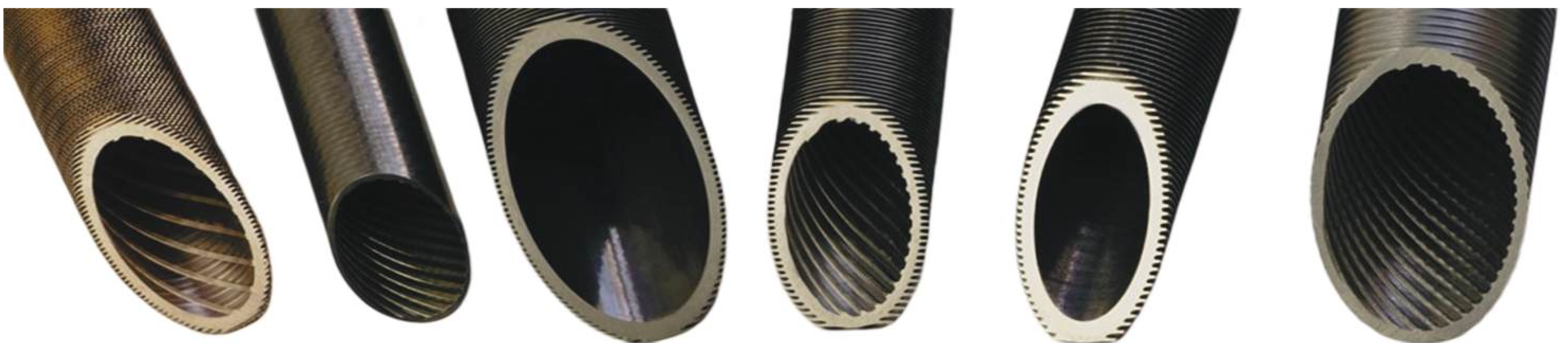

# TUBINGS

At KRN, we specialize in manufacturing a comprehensive range of Tubings that form the backbone of heat exchangers, condensers, evaporators, boilers, and industrial piping systems. Engineered with precision and reliability, our tubing solutions are available in copper, stainless steel, cupro-nickel, brass, and carbon steel, providing versatility across diverse applications.









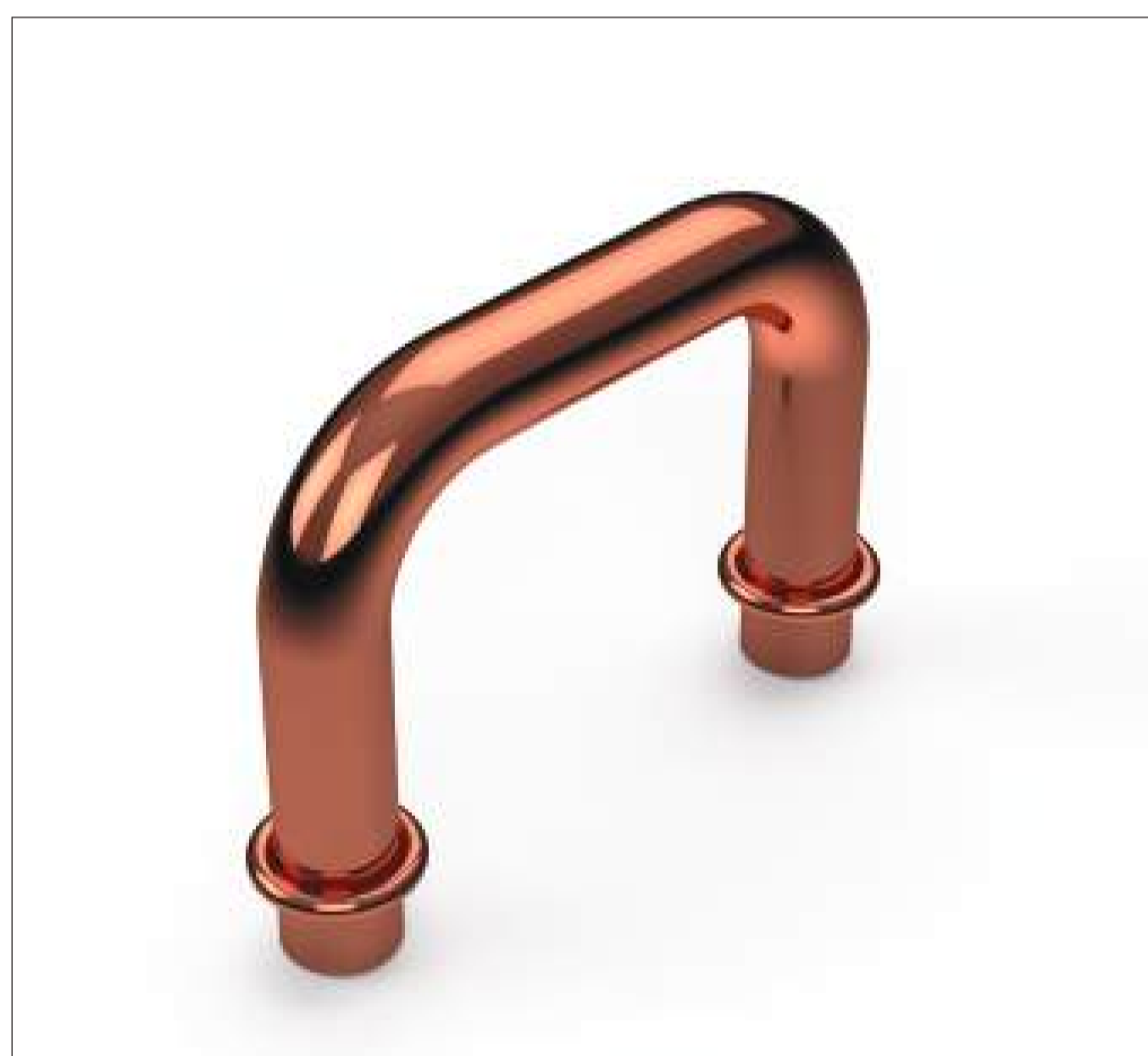

We offer:

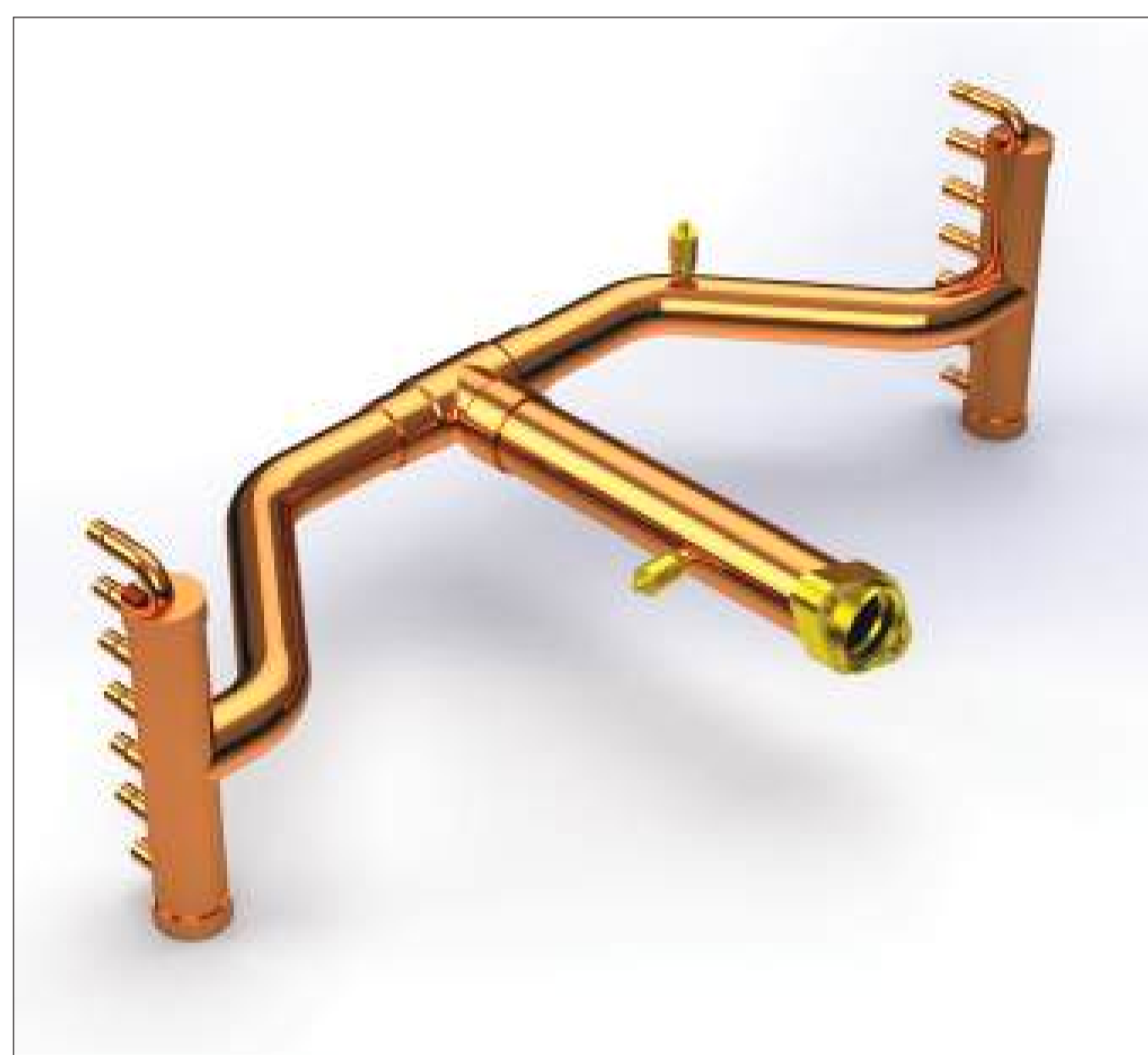
U Bend & C Bend Tubings in sizes: **5 mm, 6.35 mm, 7 mm, 7.94 mm, 9.52 mm, and 12.7 mm**

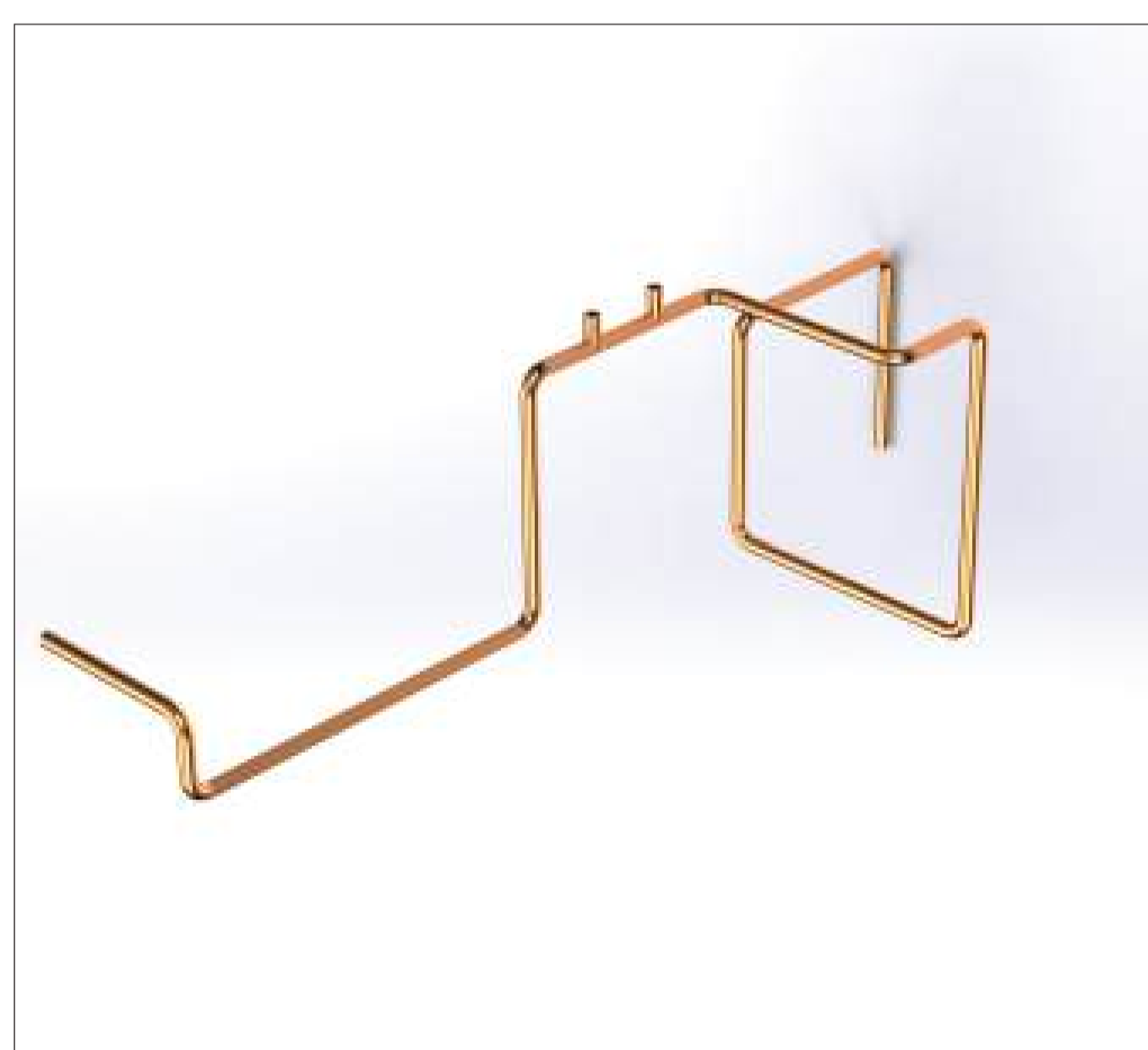
Headers & Straight Tubings ranging from **3 mm to 101.6 mm**



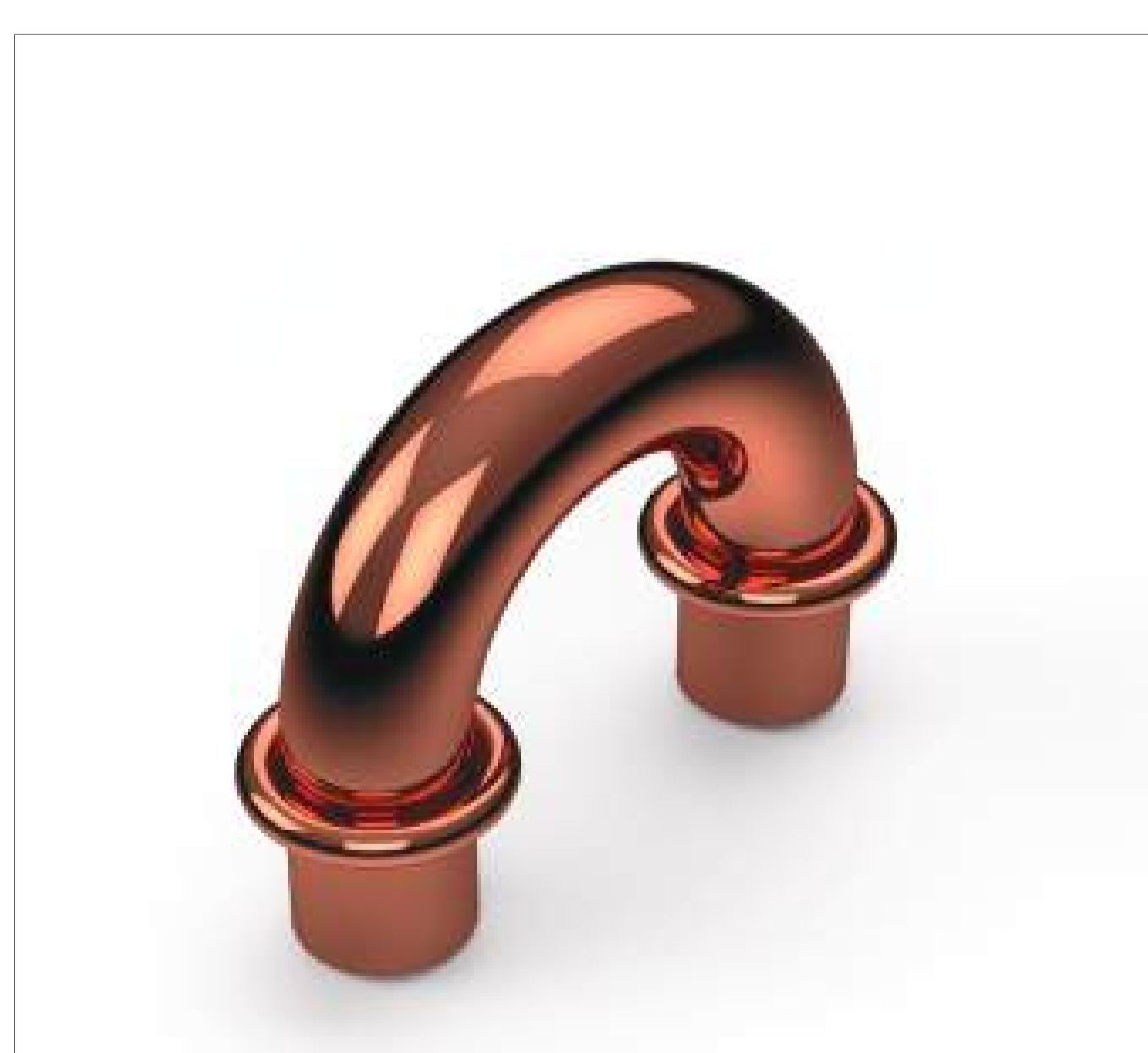









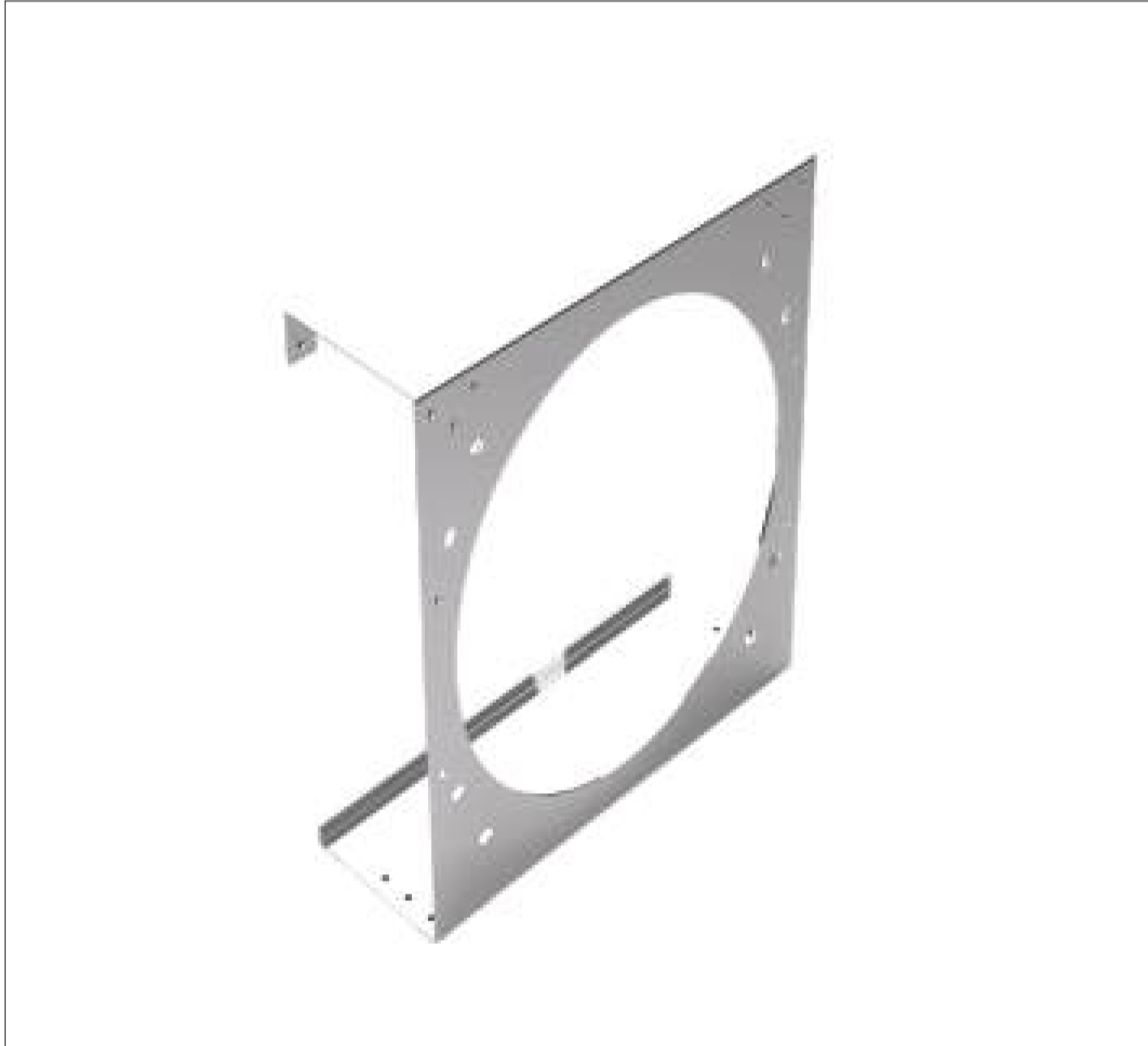

With options in multiple diameters, wall thicknesses, and surface finishes, our tubes are ideal for high pressure steam lines, seawater cooling systems, and hygienic fluid transfer in food and pharmaceutical industries. Each tube undergoes stringent hydro, pneumatic, or eddy current testing to ensure leak-free performance and full compliance with international standards.

Designed for efficiency, durability, and adaptability, KRN Tubings deliver trusted solutions for HVAC, marine, industrial, and energy applications.

Tubings/ Piping	Headers	U - Bend	C - Bend	I - Kit
				
C BEND	C BEND	HEADER	HEADER	
				
I KIT	TUBING	TUBING	TUBING	
				
MS HEADER	U BEND	U BEND	SS HEADER	

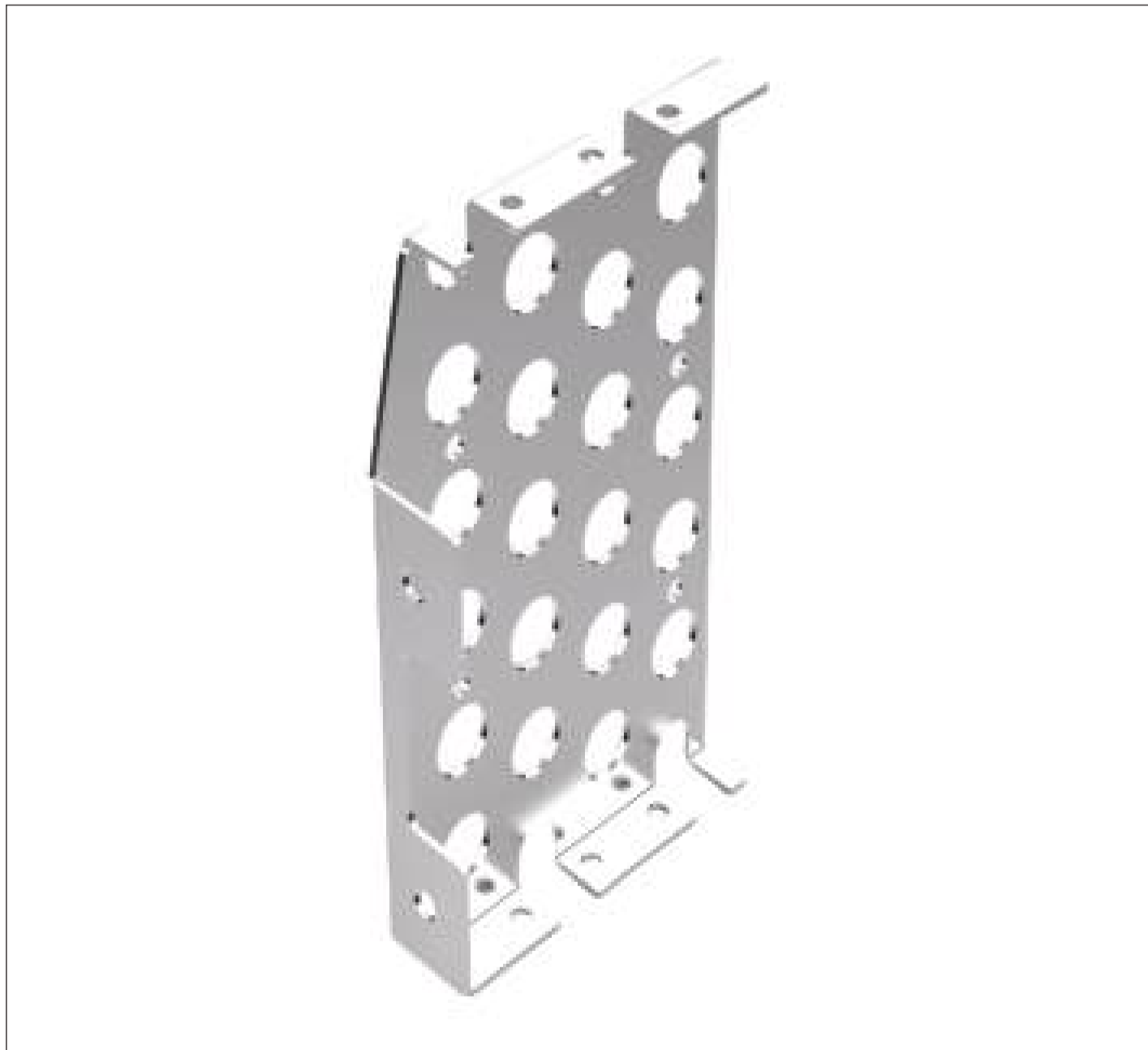
# SHEET METAL

Our precision-engineered Sheet Metal components form the structural backbone of heat exchangers, HVAC systems, and industrial equipment. Manufactured using advanced fabrication techniques like CNC punching, laser cutting, bending, stamping, and welding, our sheet metal solutions are known for their durability, dimensional accuracy, and corrosion resistance. Available in galvanized steel, stainless steel, and aluminum, these components are designed to withstand harsh operating environments while maintaining structural integrity. From casings, housings, and enclosures to brackets, panels, and supports, KRN's sheet metal products cater to diverse OEM and industrial applications. With options for powder coating, anodizing, or galvanizing, our sheet metal solutions offer long-lasting protection and a professional finish.

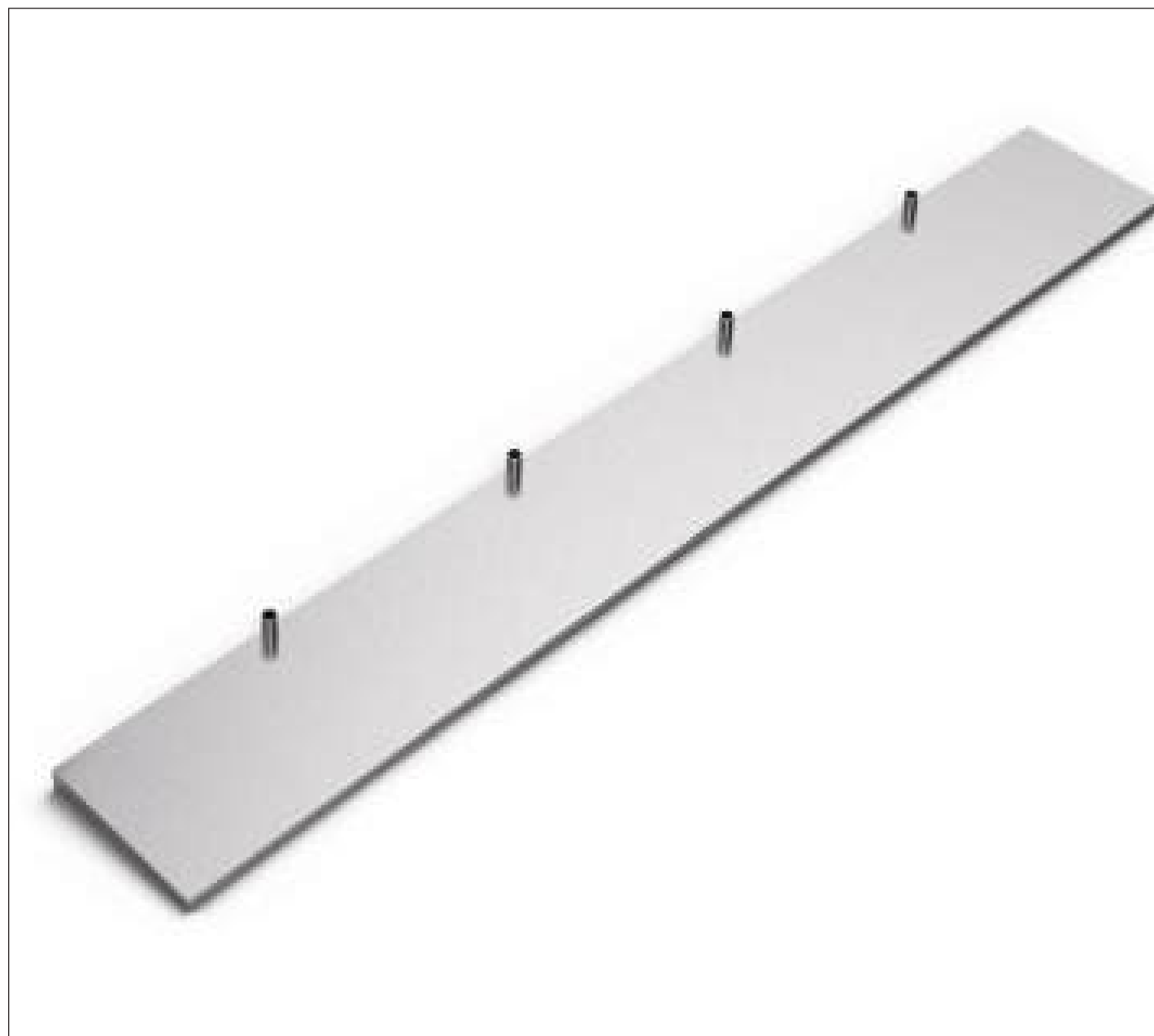
SHEET METAL COMPONENTS	FABRICATION PARTS	SS COMPONENTS	POWDER COATED PARTS
			
			
			
			

# PSYCHROMETRIC TESTING

The Multi Chamber Test Facility is capable of testing HVAC systems under extreme indoor (5°C to +50°C) and outdoor (-20°C to +60°C) conditions with humidity up to 95%. It supports testing up to 55 TR for VRF and chillers, complies with IS/ISO/AHRI/EN/GB/SASO standards, and covers a wide range of domestic and commercial air-conditioning products.

## Multi Chamber Test Facility - Capabilities

Temperature - Indoor Room	5 to +50 °C
Temperature - Outdoor Room	-20 to +60 °C
RH %	30 to 95 %
Air Flow range (CFM)	150 to 16000
Test Capacity - Lab A (Cooling & Heating)	0.5 to 12 TR
Test Capacity - Lab B (Cooling & Heating)	5 to 40 TR
Multi Chamber - Combined Lab A & B	VRF - 55 TR - Chiller 55 TR (Air Cooled)
Test Standards	All applicable - IS / ISO / AHRI / EN / GB / SASO
Refrigerants	R 32, R 454B, R 410 & R 290
Voltage	30 to 600 Volts
Frequency	10 to 100 HZ
Products	Coils/fan coils Domestic Air conditioners - Window, Wall mounted, Cassette, Floor standing, Console, High Static Commercial Air Conditioners: Ducted, Packages, Roof top units, Inverter AC, AHU, Chillers Heat pumps, Domestic air coolers, Precision air conditioners Bus, Truck and Train AC

# Testing Facility



Contamination testing setup



Helium leak testing



Burst test setup

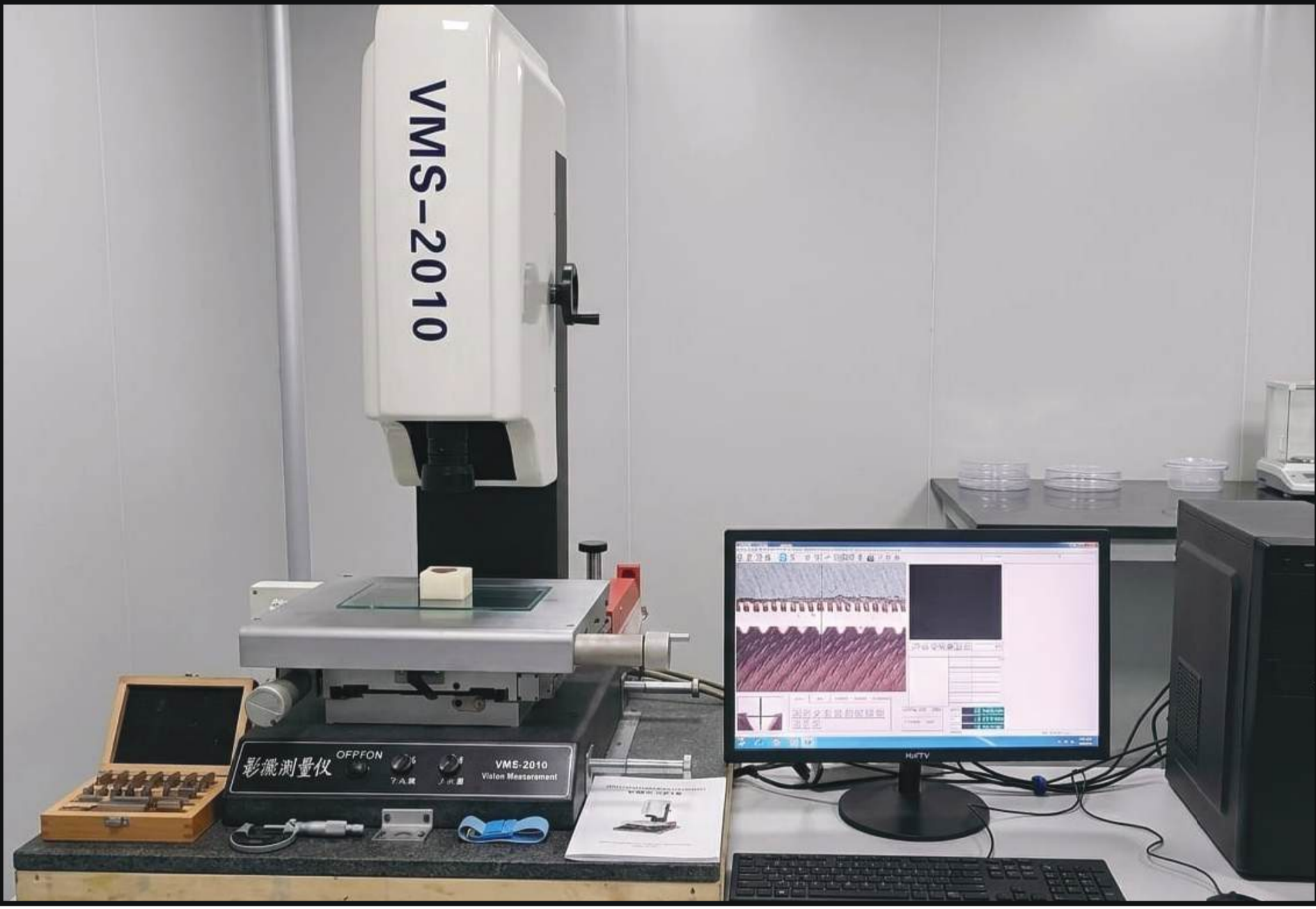

VMS\_2010



UTM Machine

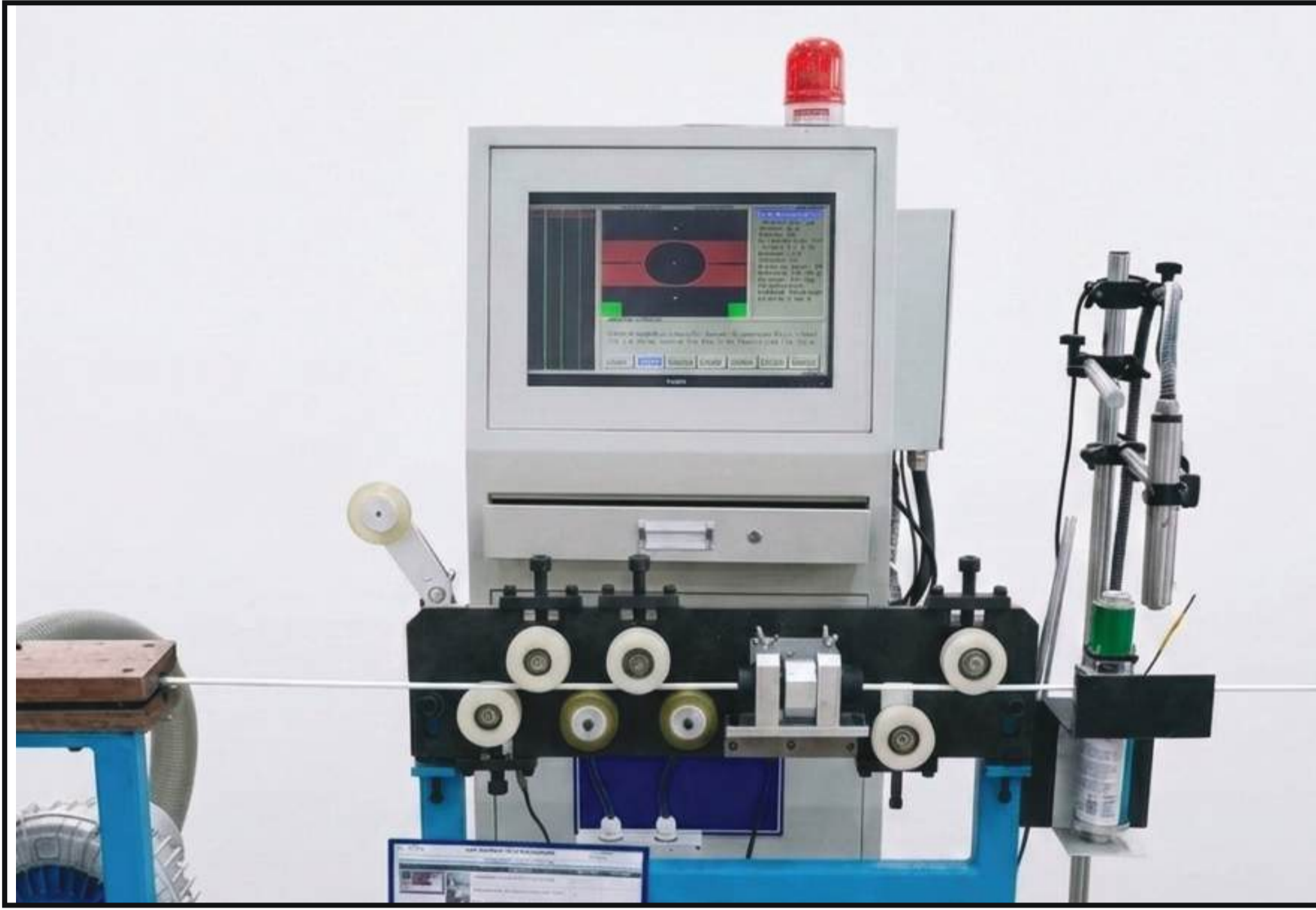

Eddy Current test setup



Air and oil pressure drop testing setup or wind tunnel testing



Hardness tester



Powder coating testing



Pressure cycle testing



Salt Spray Testing

# COATINGS

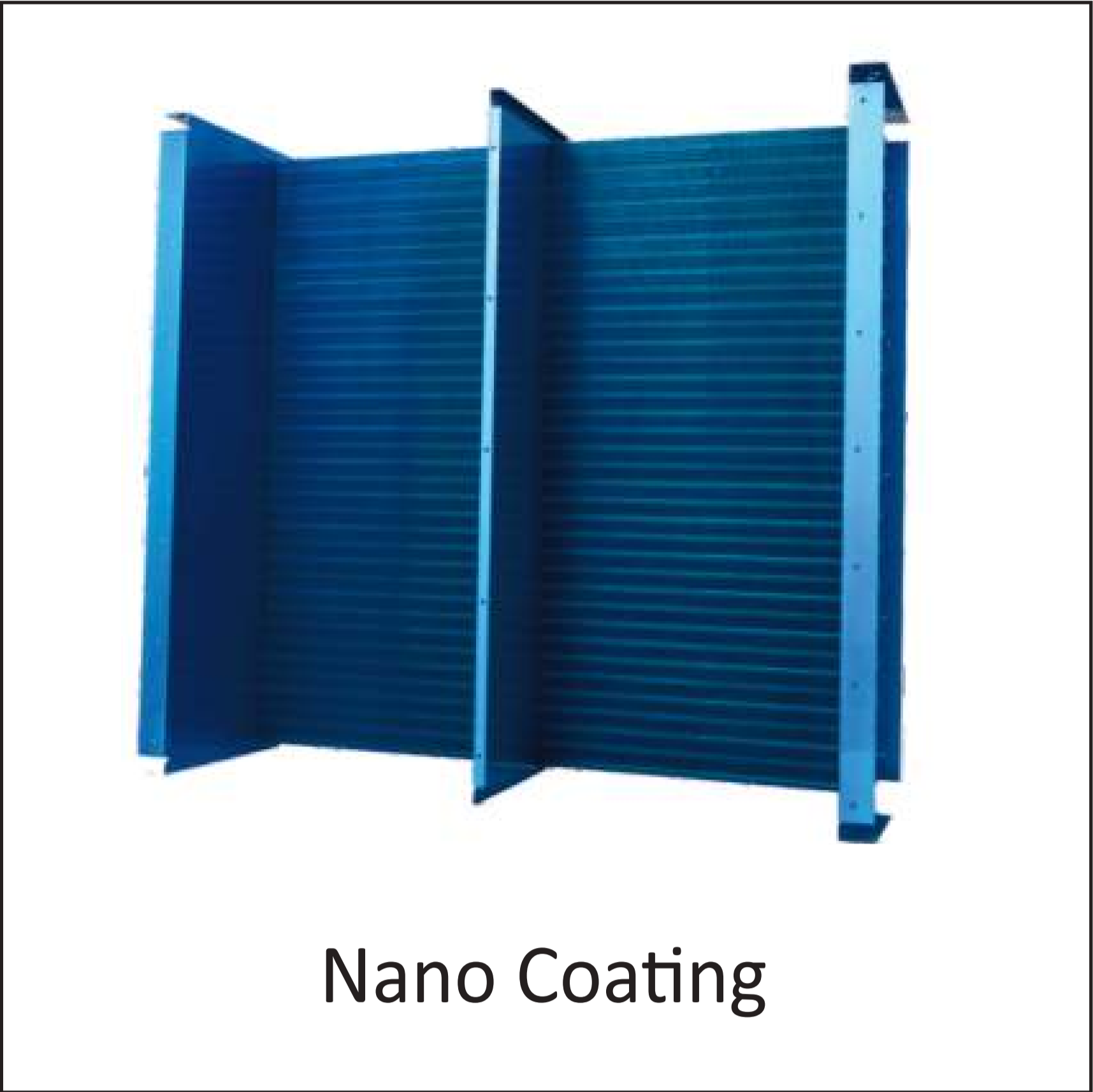

# UNIT - 1 : KRN HEAT EXCHANGER & REFRIGERATION LIMITED

At F-46 to 49, E.P.I.P. RIICO Industrial Area, Neemrana, Distt. - Alwar (Rajasthan)



# UNIT - 2 : KRN HVAC PRODUCTS PVT. LTD

At SP 1-24 at industrial Area, Kolila Joga, Neemrana, Distt. - Alwar (Rajasthan)



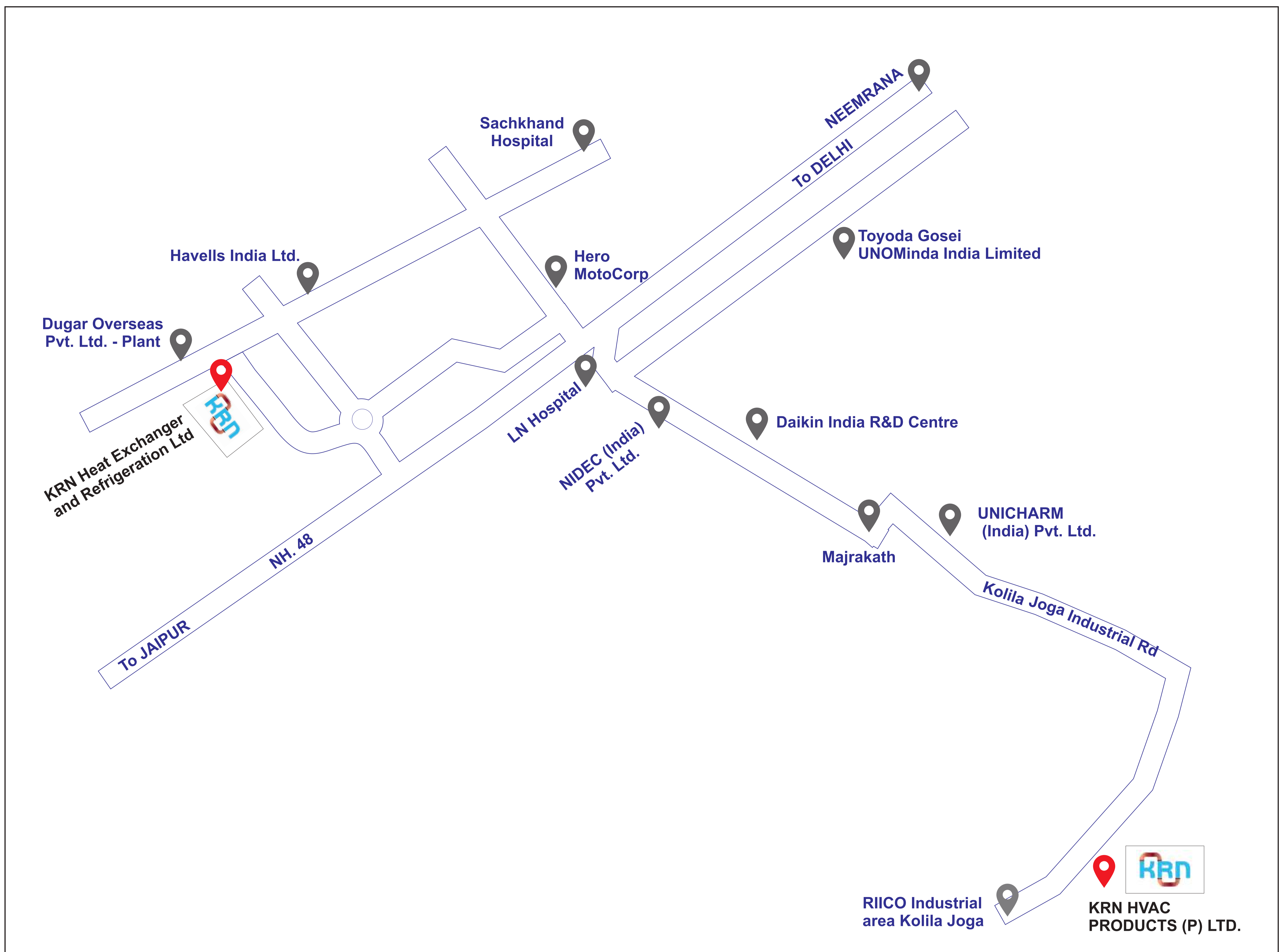

## For More Information Contact Us.

### India Sales :

✉ vivekchauhan@krnheatexchanger

☎ +91-9116629182

### Export :

✉ pragnesh@krnhvac.com

☎ +91-9727376956

🌐 [www.krnheatexchanger.com](http://www.krnheatexchanger.com)

🌐 [linkedin.com/company/krn-heat-exchanger-refrigeration-limited](https://www.linkedin.com/company/krn-heat-exchanger-refrigeration-limited)

📍 **KRN HEAT EXCHANGER AND REFRIGERATION LTD.**  
F-46 to 49, E.P.I.P. RIICO Industrial Area, Neemrana,  
Rajasthan, India - 301705

**KRN HVAC PRODUCTS (P) LTD.**  
SP 1-24, RIICO Industrial Area, Kolila Joga, Neemrana,  
Rajasthan, India - 301020



Scan For Location



Unit 1



Unit 2